

**INSTALLATION AND OPERATION MANUAL  
FOR SUPERTRACK MODEL K5  
Ku-BAND TV-RO ANTENNAS**



**KNS Inc.**

Tel)+82-42-932-0351~2

Fax)+82-42-932-0353

Web) <http://kns-kr.com/>



28.03. 2011



KNS SuperTrack systems are manufactured in the Republic of South Korea.

#### Copyright Notice

All Rights Reserved. The information contained in this document is proprietary to KNS, Inc. This document may not be reproduced or distributed in any form without the consent of KNS, Inc. The information in this document is subject to change without notice.

Copyright 2011 KNS, Inc.

## Revision History

Revision	Date	Description	By	Remarks
1.0	14. 01. 2011	Initial Release(PCU Ver. K1.040 & ACU Ver. 1.00)	Hong	
1.1	16. 06. 2011	Change the photo of packing box(PCU Ver. K1.050 & ACU Ver. 1.10)	Hong	

# Contents

<b>1. Introduction</b> .....	<b>1</b>
1.1. Purpose .....	1
<b>2. Installation</b> .....	<b>2</b>
2.1. Site Selection .....	2
2.2. Unpacking the Unit .....	4
2.3. Equipment and Cable Installation .....	5
2.4. Antenna Unit Mounting .....	6
2.5. ACU Mounting .....	9
2.6. Gyro Connection(Optional).....	10
2.7. Cable Connection.....	13
<b>3. Operation</b> .....	<b>16</b>
3.1. Front Panel Functions .....	16
3.2. ACU Display Operation .....	19
3.3. Set-up Mode .....	22
<b>4. How to Operate SCS</b> .....	<b>31</b>
4.1. Connect to PC .....	31
4.2. Setting the parameters of the satellite .....	33
4.3. Skew Control .....	40
4.4. Antenna State .....	42
4.5. Installer.....	45
<b>Appendix A: Example of Setting the Satellite's Parameters Using SCS</b> .....	<b>50</b>
<b>Appendix B: Error Code Definition</b> .....	<b>55</b>
<b>Appendix C: Specifications</b> .....	<b>59</b>
<b>Appendix D: Satellite Information</b> .....	<b>60</b>
<b>Appendix E: Radome and Antenna Mounting Holes Layout</b> ..	<b>64</b>

# 1. Introduction

## 1.1. Purpose

The purpose of this manual is to provide the necessary information required by the end user, customer and installer to successfully install the K5 antenna and controller and to program the KA-80 for operation.

It is recommended that all personnel responsible for operating K5 systems should know which type of system they have, read and understand the basic terms, and be familiar with the operation of these systems.

Although installations may be completed by the customer's preferred personnel, it is also recommended that personnel be trained in the KNS suite of equipment installation procedures and trained by the relevant KNS Inc. experts.

## 2. Installation

### 2.1. Site Selection

Determine the optimum mounting location for the antenna radome assembly. It should be installed where:

1. The antenna has a clear line-of-sight view of as much of the sky as is practical. Choose a location where masts or other structures do not block the satellite signal from the dish as the boat turns.
2. The antenna is situated at least 5m away from other transmitting antennae (HF, VHF and radar) that may generate signals that may interfere with the SuperTrack K series antenna. The further away the SuperTrack K series antenna is from other such antennae, the less impact their operation will have on it.

The antenna radome assembly should be rigidly mounted on the boat. If necessary, reinforce the mounting area to ensure that it does not flex due to the boat's motion or vibration.



*Figure 2-1 Best Location I*



*Figure 2-2 Best Location II*

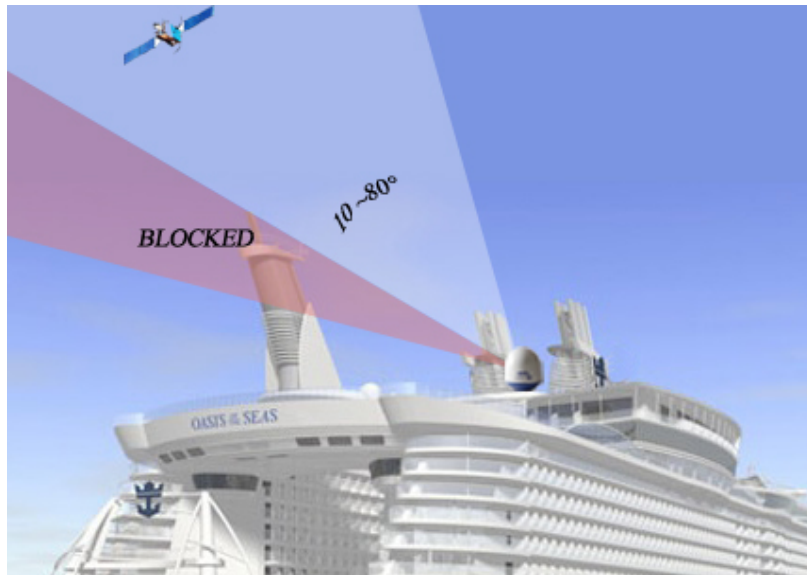

*Figure 2-3 Antenna Blockages*

## 2.2. Unpacking the Unit

Cut the band and remove the items of antenna equipment. Do not turn the box on its side to tip or roll out the product, or turn the box upside down to remove it.



**Figure 2-4 Unpack the Antenna**



## 2.3. Equipment and Cable Installation

The coax connector bracket beneath the radome is labeled. The functional assignment of these labels is as follows:

K5 Connectors

RF1: Connect to the multi-switch (Vertical Low).

RF2: Connect to the multi-switch (Horizontal Low).

RF3: Connect to the multi-switch (Vertical High).

RF4/ACU: Connect to the ACU.

**NOTE:** Unused coax connections (on the connector bracket) **MUST** be terminated with a 75ohm terminator.

**NOTE:** We recommend the following cable types for cable lengths:

-within 20m: RG6

-within 50m: RG11

-within 100m: LMR400

-within 200m: LMR600

**NOTE:** Impedance of cable is 75ohm. Also you can select the other cable types. You have to keep in mind that we recommend all attenuation of cable is under 20dB at 2.5GHz.



**Figure 2-5 RF Connector Bracket**

## 2.4. Antenna Unit Mounting

Drill four bolt holes and cut out a cable access hole on the mounting site. (See reference appendix.)

Position the base plate over the mounting holes and the cable access hole, and then align the radome base plate's "Bow" label (shown in Figure 2-6) with the ship's bow.



**Figure 2-6 "BOW" Label of the Radome Base**

1. Connect the data/power and the RF cables from below decks to the base plate with a 7/16" wrench, applying 30 pounds of torque. Check the label on both ends of each RF cable to match its antenna base-plate connector. Do NOT use Teflon gel on the cable fittings as it reduces signal strength at high frequencies.
2. Install flat washers and spring washers and a mounting bolt to each mounting hole of the radome base from the underside of the mounting surface. Apply Loctite 241 to the threads of the mounting bolt up near the mounting surface and tighten each of the 4 bolts to 24 in-lb (21 kg-cm) of torque [finger tight, then about 1/4 turn tighter] with a wrench. DO NOT OVER-TIGHTEN. You have to install mounting bolts of the proper length. If a bolt is too long, the extra length of threaded rod that extends above the radome base should be cut off.

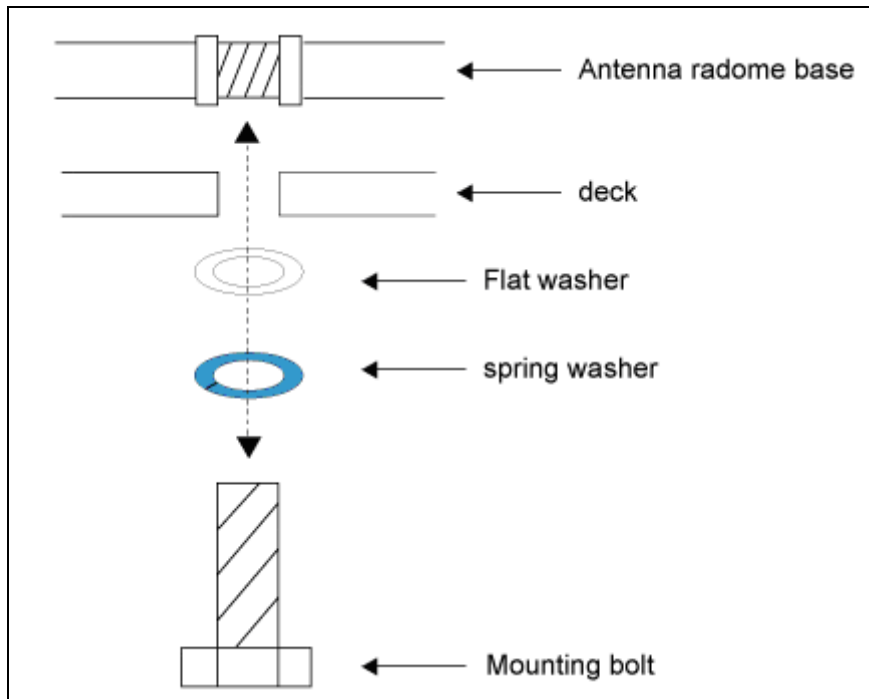

**Figure 2-7 Tighten the nuts from below**

3. Remove the screw and wire tie holding the Antenna. Please refer to Figures 2-8 below.

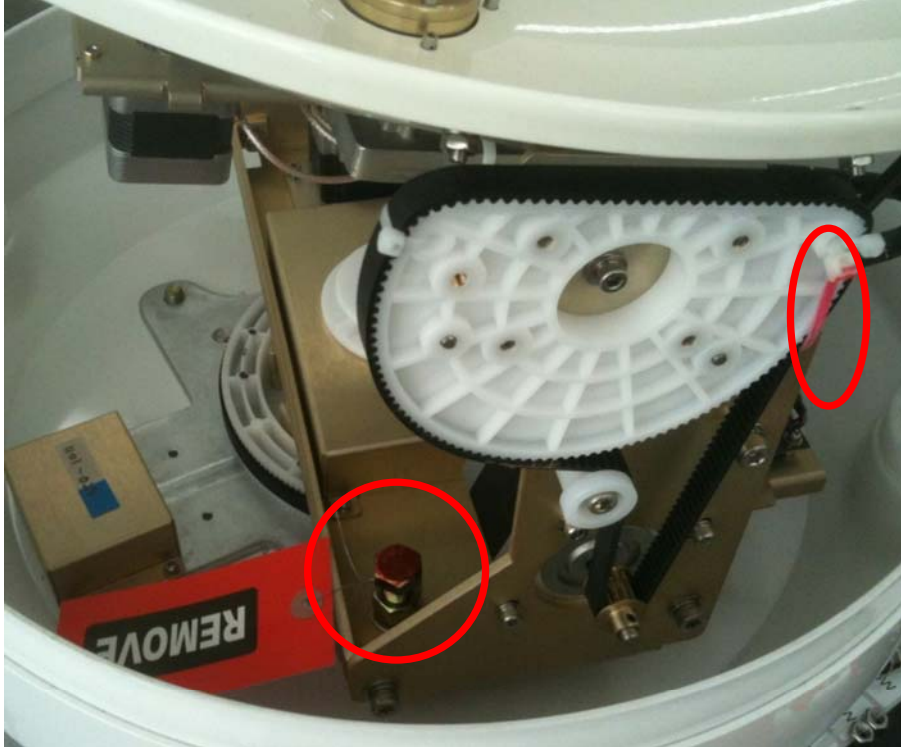

**Figure 2-8 Fixed the Forms and Wire Ties**

## 2.5.ACU Mounting

The ACU may be mounted either horizontally or vertically.

1. The ACU should be placed in a dry location that is convenient for the user.
2. It must be situated in a place that is not susceptible to magnetic interference; nor must it be situated on a level surface.
3. It should be placed so that the LCD display is visible and the buttons are easily accessible.



Figure 2-9 KA-80 ACU

## 2.6. Gyro Connection(Optional)

The SuperTrack K5 accepts NMEA-type gyro via NMEA port of the ACU back panel. Connect the NMEA port with a ship's gyro using a 9-pin connector (female type).

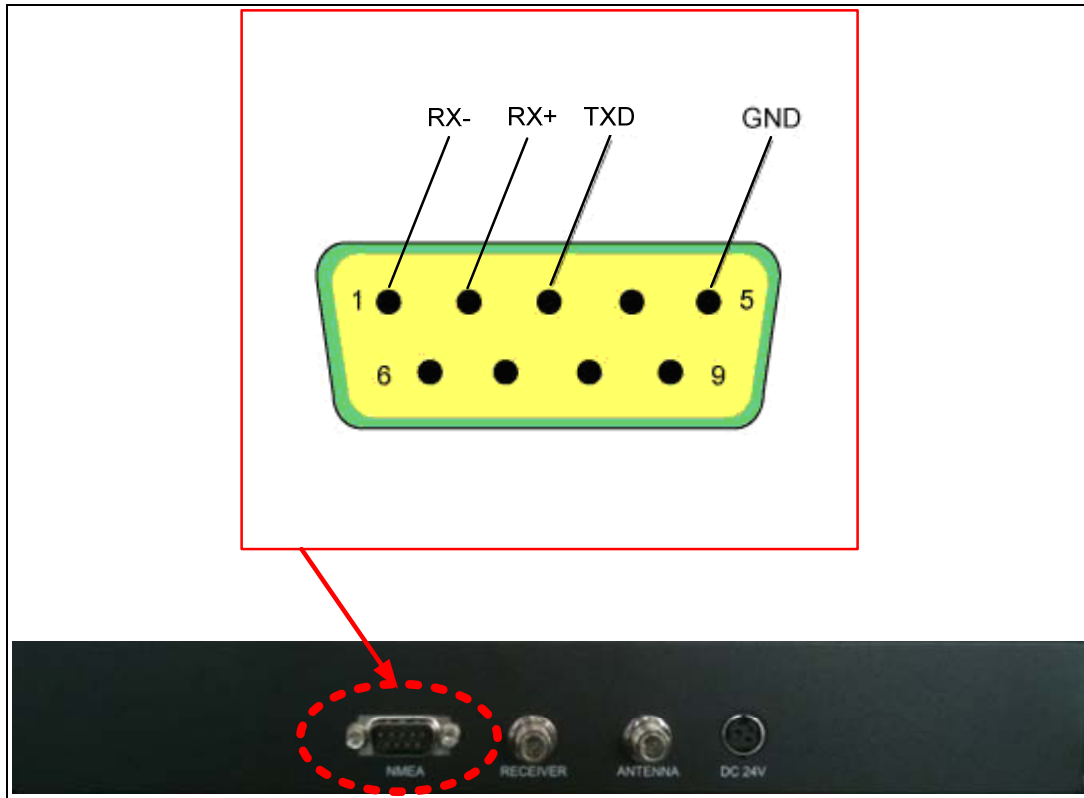

Figure 2-10 NMEA Connector



Figure 2-11 Female-type 9-pin Connector

### Gyro Cable Connection

The cable connection differs according to the type of NMEA. Connect the NMEA port with the ship's gyro, as indicated in Figures 2-12 and 2-13 below.

Pin No.	Pin Name
1	RX-
2	RX+
3	TXD
4	Dummy
5	GND
6	Dummy
7	Dummy
8	Dummy
9	Dummy

Table 2-1 Using the pin number of the ACU Connector for the NMEA type

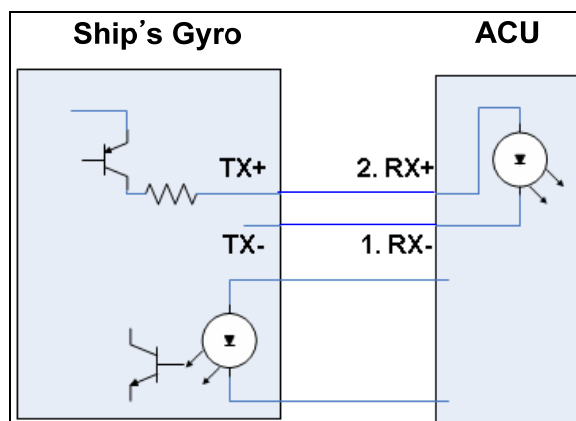

Figure 2-12 Cable Connection NMEA 422/485

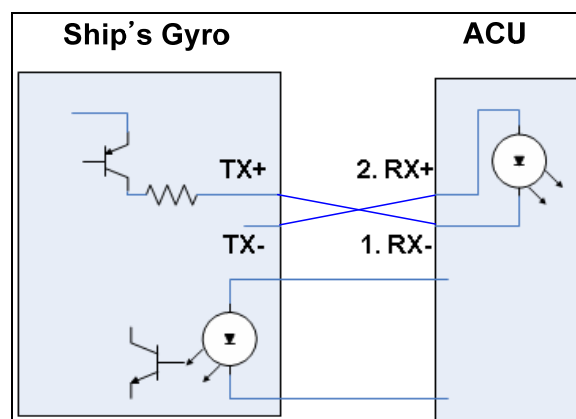

Figure 2-13 Cable Connection NMEA 232

**NOTE:** KA-80 ACU can accept the various format of NMEA, as follow: HDT; HDG; HDM.

**NOTE:** SuperTrack K5 will be initializing when NMEA signal is accepted via NMEA. Installer doesn't need any setting on the ACU and antenna when connects the NMEA signal.



## 2.7. Cable Connection

For the SuperTrack K5 to work, you must connect the RF cables to your satellite TV receiver(s). Each RF cable must be an RF (75 ohms) cable fitted with F-type connectors. The RF cables should already be connected to the antenna base plate. There should be one ~ four coax cables routed from the ACU to the Antenna unit according to your configurations. Note that Data and Power are transmitted through a single coax cable. **This cable should be connected to the RF4/ACU labeled “RF connector of the antenna base plate” and the connector of the ACU labeled “ANTENNA.”** The remaining coax cable routing depends on your configuration. Due to the signal polarization of the satellites, it is possible for the SuperTrack K5 to support more than two satellite TV receivers aboard a boat. To install more than two satellite TV receivers/TV pairs, an active multi-switch is placed between the Antenna Unit and the Satellite TV receivers. The following sections provide details for the installation of both a single satellite TV receiver and multiple satellite TV receivers.

To connect the SuperTrack K5 to your satellite TV receiver(s), choose one of the following configurations (based on the number of satellite TV receivers you will connect to the antenna):

Option 1 - Connecting one satellite TV receiver for one satellite

Option 2 - Connecting multi satellite TV receivers

### ***Connecting one satellite TV receiver for one satellite (Only use the ‘HH’ polarity of the satellite)***

One satellite TV receiver for one satellite is the simplest type of cable installation. Only two coaxial cables should be connected between the antenna unit and the satellite TV receiver, as shown in Figure 2-14. One end of the RF cable should already be connected to the connector labeled “RF4” on the base of the SuperTrack K5 antenna. Connect the other end of the RECEIVER cable to the satellite TV receiver connector labeled “LNB,” “ANT/SAT,” or “satellite IN.” And, the “RF4/ACU” connector of the antenna base plate must also be connected to the “ANTENNA” connector of the ACU. In this configuration, every satellite should be selected manually using the ACU.

**NOTE:** Before you connect an RF cable to a satellite TV receiver, turn on the satellite TV receiver and TV and verify that there is no AC voltage on the satellite TV receiver’s

input connector, as measured between the center conductor and the shield. If AC voltage is present on the connector, DO NOT connect the RF cable until you have corrected the problem. This is a potentially dangerous condition that will damage the antenna's electronics.

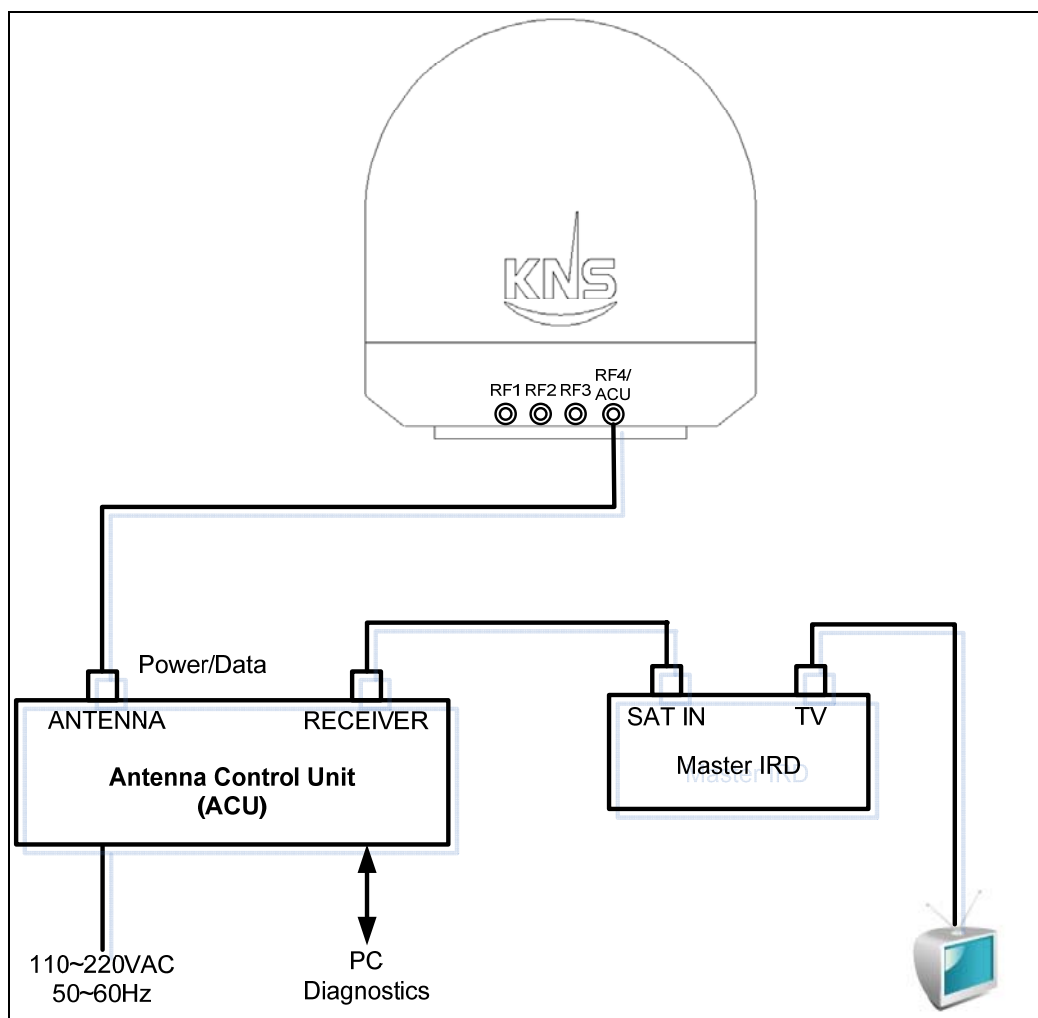
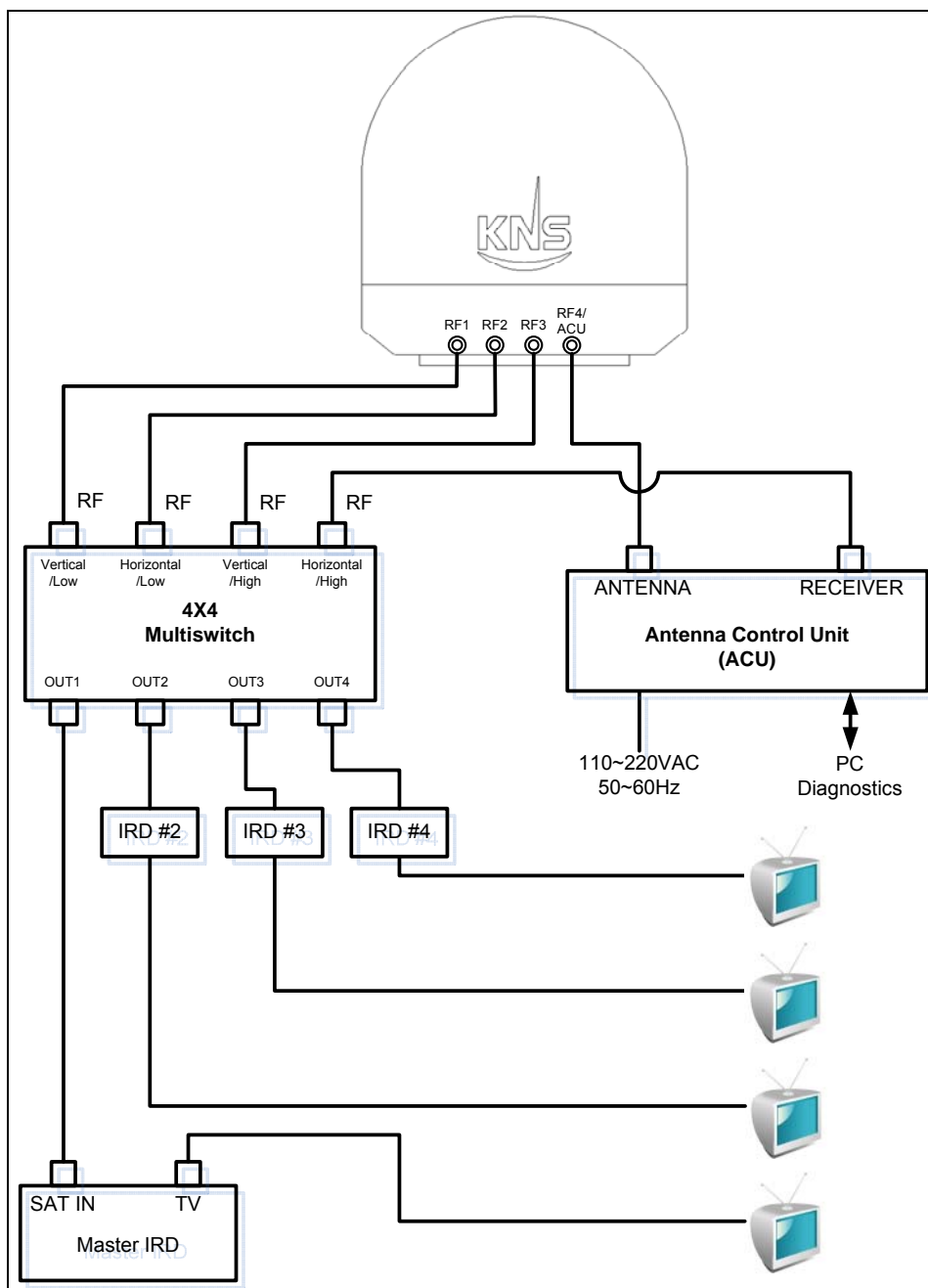

**Figure 2-14 One Satellite TV Receiver Installation**

**Connecting multi satellite TV receivers (Use of the all polarity of satellite)**

In European systems that come with a Quattro LNB (optional Quad LNB), all four RF outputs from the SuperTrack K5 antenna should be connected to the multi-switch. Connect each of the satellite TV receiver's inputs to the output connectors on the multi-switch. Connect the multi-switch unit in accordance with the manufacturer's instructions. Figure 2-15 shows an example of a European multi-switch (4 inputs and 4 outputs) configuration.

- RF1: Low Band Vertical
- RF2: Low Band Horizontal
- RF3: High Band Vertical
- RF4: High Band Horizontal



**Figure 2-15 Four Satellites TV Receivers Installation with European LNB**

**NOTE:** If you want use more satellite TV receivers than four, you can choose 8 outputs or 16 outputs.

## 3. Operation

### 3.1. Front Panel Functions

1. **MENU** button – Press the MENU button for more than 3 seconds to enter the set-up mode. When you want to escape from the set-up mode, press MENU again for more than 3 seconds. Another function of the MENU button is that of checking the error message when the K5 makes an error. When the error LED is on, press the MENU button briefly. Then, you will be able to see the hexadecimal error message. Please press the NEXT button for about 2 seconds to clear the error. If you press MENU briefly again, you can go back to normal operation.

**NOTE:** KA-80 ACU can display the error message as binary. Press the MENU button and press NEXT button for 3 seconds. Then, you will be able to see the binary error message.

**NOTE:** Operator can make sure the communication status of ACU and antenna as below when press MENU and press SEARCH shortly again. Packet means the number of command from ACU, loss means the number of loss on the PCU. The more loss this display, communication status is not good.

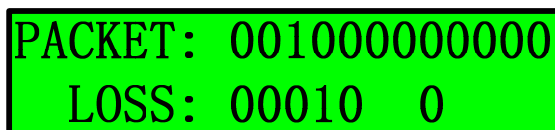

```
PACKET: 001000000000  
LOSS: 00010 0
```

*Figure 3- 1 Packet Loss*

2. **SLEEP** button – Press the SLEEP button to enter the sleep mode when antenna is tracking the satellite. The antenna does not conical scan when the TRACK button is pressed. Its function can reduce the noise of motor when vessel is anchored at the dock or calm shore. This button is also used to scroll left (◀) in the menu.

3. **NEXT** button – Press the NEXT button to select your preprogrammed next satellite. When your desired satellite is displayed, stop pressing NEXT, and then, after 3 seconds, the antenna automatically searches for your desired satellite.

Use this button when you want to scroll right (▶) in the menu.

4. **M/C** button – Press M/C for more than 3 seconds to enter computer link via RS 232. When you want to escape from computer link, press M/C for more than 3 seconds. This button is also used to scroll up (▲) in the menu.

5. **SEARCH** button – Press SEARCH for more than 3 seconds to re-search for the current satellite. This button is also used to scroll down (▼) in the menu.

6. **PWR** button (Power button) – Use this button when you want to turn on/off the antenna unit power.

7. **TRACK LED** – **Blinking** indicates that the antenna is searching for the satellite.

**ON** indicates that the antenna is tracking the satellite.

**OFF** indicates that the antenna is in the stall mode or initializing.

8. **GPS LED** – **Blinking** indicates that the antenna has distinguished the GSP but that the GPS data is invalid.

**ON** indicates that the antenna is receiving valid GPS data.

**OFF** indicates that the GPS antenna is not installed or is malfunctioning.

9. **DiSEqC LED** – **Blinking** indicates that DiSEqC option is selected as 22KHz tone.

**ON** indicates that the DiSEqC option is selected as DiSEqC 1.2 to switch satellites automatically.

**OFF** indicates that the DiSEqC option is disabled. Press the NEXT button to select the next satellite manually.

10. **ERROR LED** – **ON** indicates that one or more discrete system errors have occurred.  
(Refer to Error Code)

**OFF** indicates that no errors have occurred.



**Figure 3-2 Antenna Control Unit Front Panel**



**Figure 3-3 Antenna Control Unit Back Panel**

### 3.2.ACU Display Operation

If you turn on the power switch of the antenna control unit, you can view the steps shown in Figure 3-4 below.

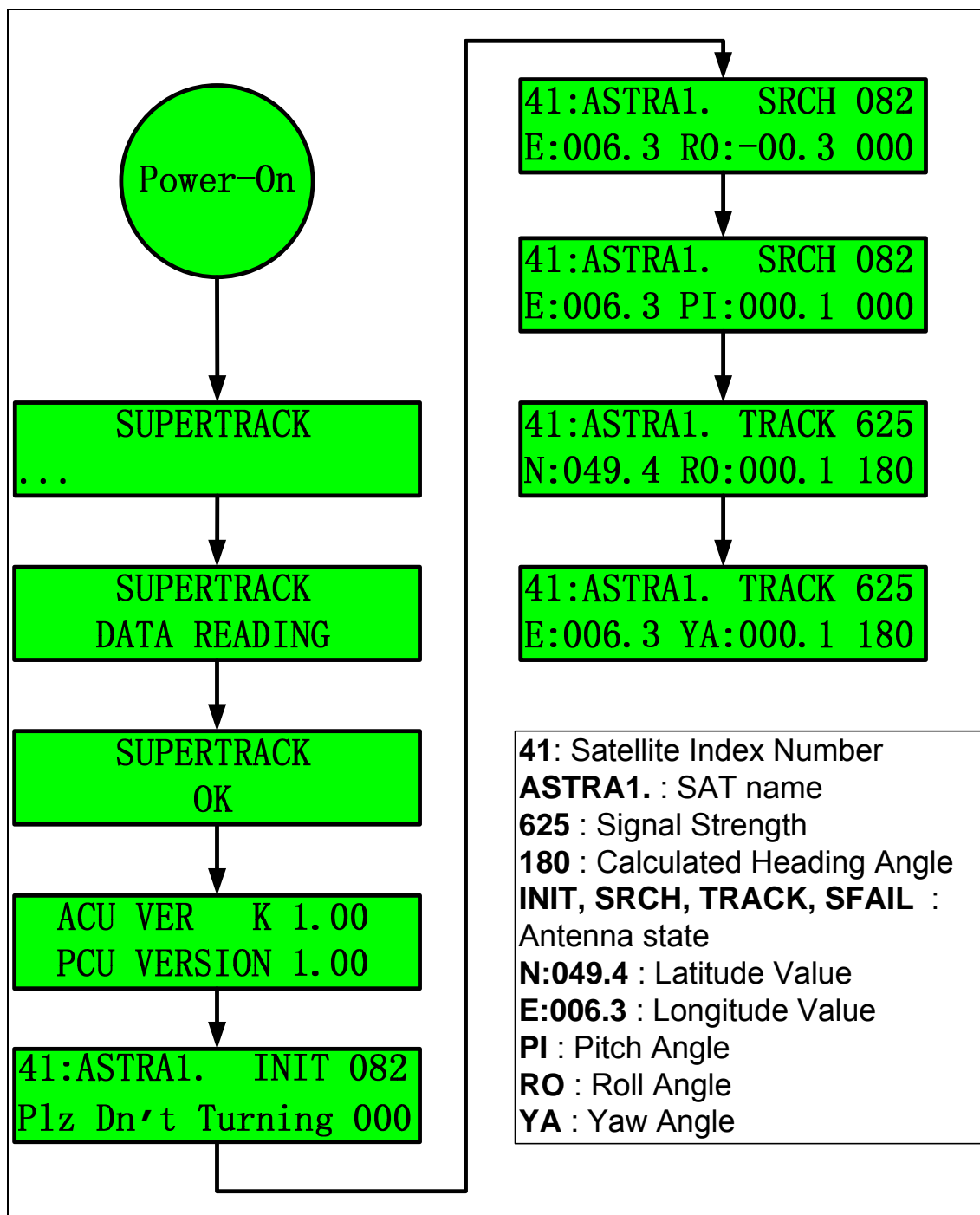

Figure 3-4 Display Flow on the ACU LCD

## Display of the Antenna State

**INIT (Initializing):** The ACU displays 'INIT' on the LCD when the antenna is initializing.

**SRCH(Searching):** The ACU displays 'SRCH' on the LCD when the antenna is searching for the satellite.

**TRCK(Tracking):** The ACU displays 'TRCK' on the LCD when the antenna is tracking the satellite.

**SFAIL(Searching Fail):** The ACU displays 'SFAIL' on the LCD when antenna isn't searching for the satellite for 3 minutes or you select a different area from your area.

**E:006.3, N:049.4(GPS data):** The ACU continuously displays the GPS data on the LCD. If KA-80 ACU is connected with ship's gyro, the ACU displays the ship's heading instead of the roll and pitch, yaw angle, as shown in Fig 3-5 below.

**PI(Pitch angle):** The ACU displays 'PI:000.0' on the LCD. It is calculated pitch angle of vessel by PCU

**RO(Roll angle):** The ACU displays 'RO:000.0' on the LCD. It is calculated roll angle of vessel by PCU

**YA(Yaw angle):** The ACU displays 'YA:000.0' on the LCD. It is calculated yaw angle of vessel by PCU

**HALT:** If the antenna experiences the same control error twice within 3 minutes, the PCU isn't supplying the torque to all motors to protect the antenna. In this case, the ACU will display 'HALT' on the LCD. The antenna continues in 'halt' mode until the ACU power has been reset.

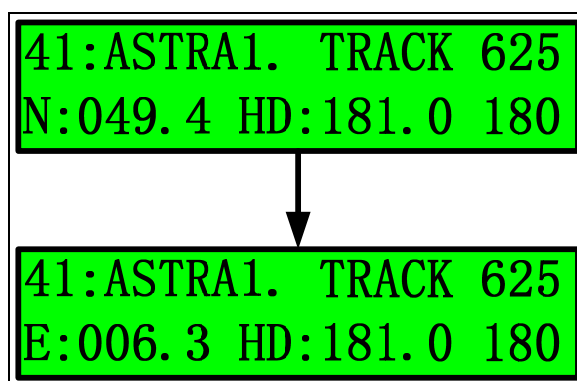

Figure 3-5 Display of tracking on gyro mode

**NOTE:** For the first power-on of the GPS antenna, it will take about 5 minutes to calculate your location from the GPS satellites' signals and configure the database.



**NOTE:** Do not push any buttons during the self-diagnosis sequence.

**NOTE:** If operator selects the 'SLEE MODE ON', the ACU displays the '#' between satellite name and status of antenna as shown in Fig 3-6 below.

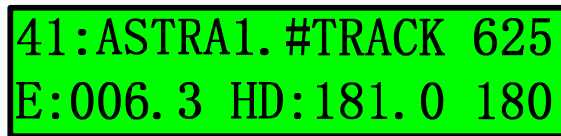

41:ASTRA1.#TRACK 625  
E:006.3 HD:181.0 180

*Figure 3-6 Display on the sleep mode*

**NOTE:** You can see the initial time on the LCD panel as shown in Fig 3-7 below during initializing. Please don't be rotated vessel during or antenna may be not searching for satellite.

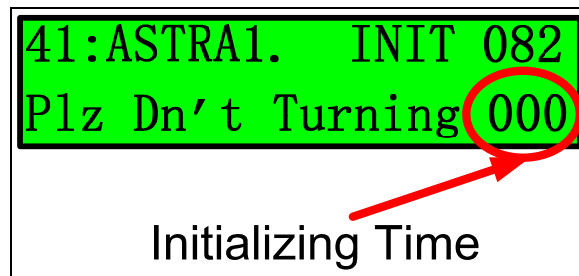

41:ASTRA1. INIT 082  
Plz Dn't Turning 000

Initializing Time

*Figure 3-7 Display the Initializing Time*

### 3.3. Set-up Mode

Initial set-up is accomplished by the installer or operator using the SETUP Mode to configure the system parameters.

Press and hold the “MENU” button for more than 3 seconds to enter the SETUP mode. To navigate the menu, press the UP or DOWN button. The set-up mode has 10 sub-menus.

#### Upgrade

The installer or operator can change and configure the current parameters of the K5 by computer.

Connect the M&C port of the ACU to the serial port or the USB port of the computer with an RS-232 cable (Cross: Female to Female), as shown in Figure 3-8.

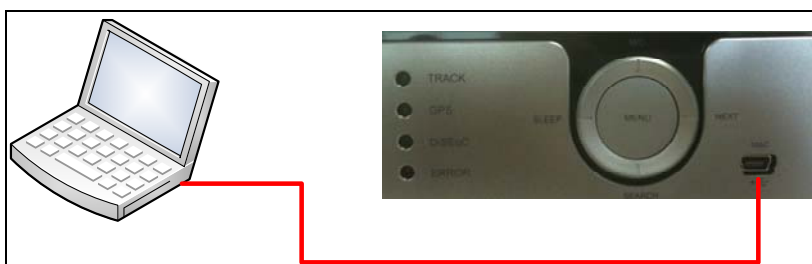

Figure 3-8 Connection ACU with Computer

If you want to connect to the PC, follow Figure 3-9 or Figure 3-10.

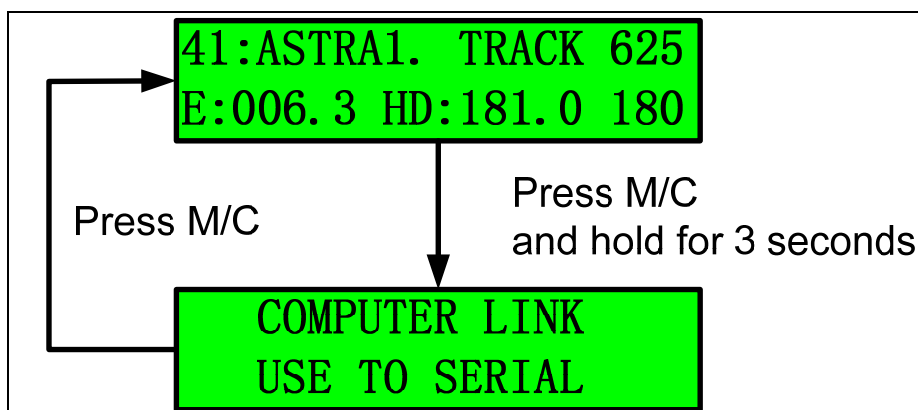

Figure 3-9 Computer Link step 1

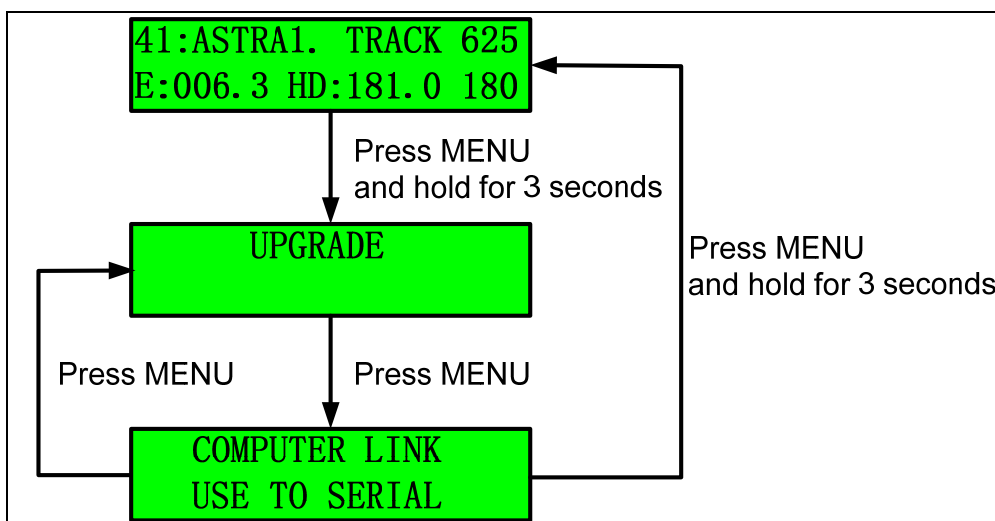

Figure 3-10 Computer Link step 2

10

### Set Latitude and Longitude

In the event of invalid GPS data or GPS breakdown, you can input the desired latitude and longitude. Refer to Figure 3-11. This data will be changed if the GPS data is valid or if the ACU power is reset.

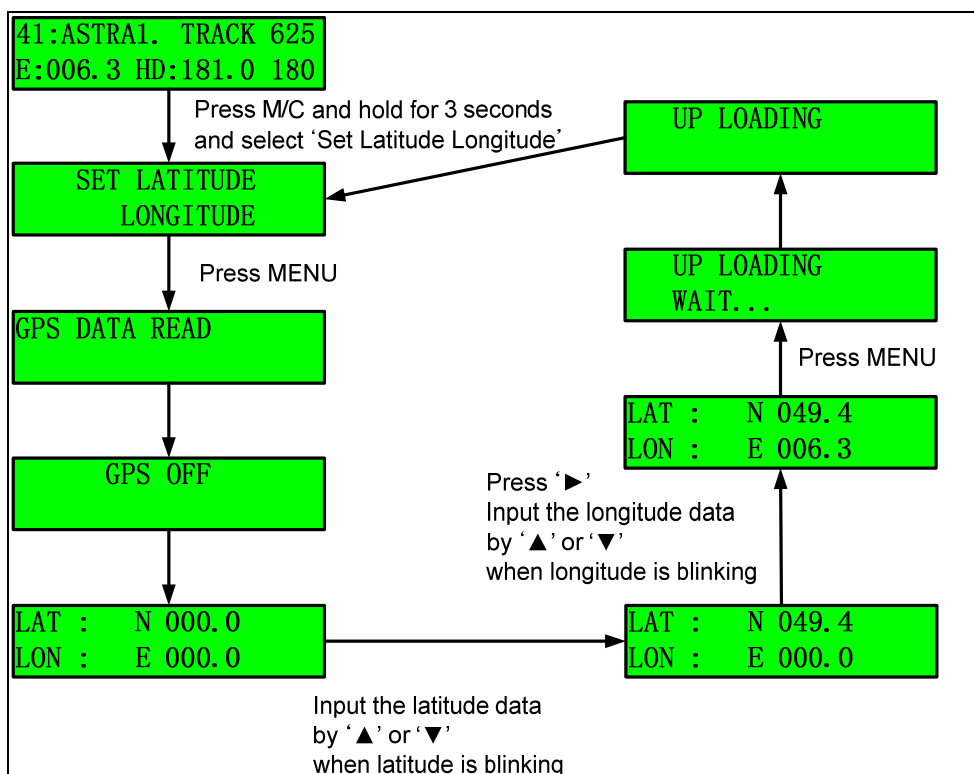

Figure 3-11 Set Latitude & Longitude step

## Program Area

Before you select your satellites, you have to select the service area from among Asia, Europe, Latin America, and North America.

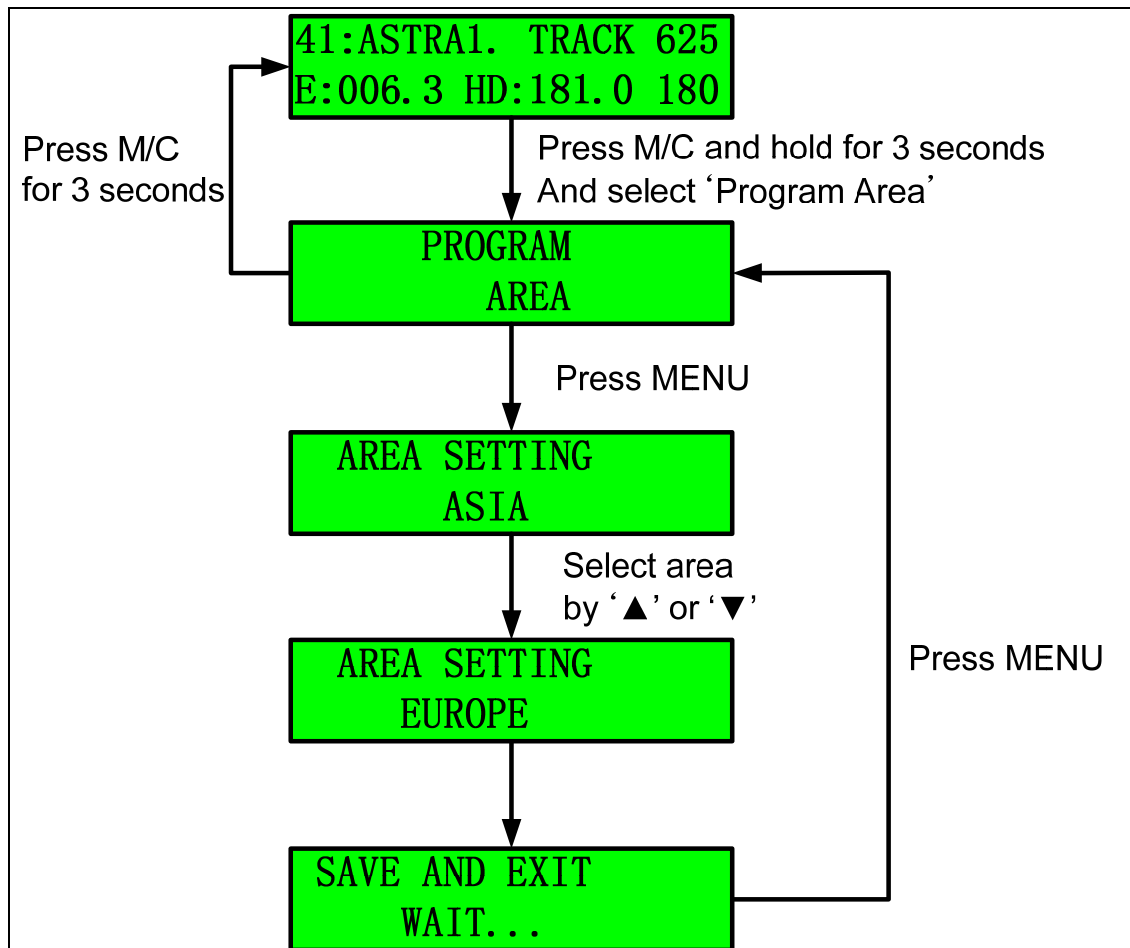

Figure 3-12 Program Area Setting Step

**NOTE:** The K5 has 80 satellite IDs, and each area has the parameters of 20 satellites, as shown below.

North America: Sat ID 1~20

South America: Sat ID 21~40

Europe: Sat ID 41~60

Asia: Sat ID 61~80

**NOTE:** If you select a different area from your area, the ACU will display SFAIL (Searching Fail) on the LCD and the antenna will point toward the appointed position after initialization.

**NOTE:** All satellites on the same area share the LNB local frequency.

## Program Satellite

The user can select up to 5 desired satellites on KA-80 ACU. The user has to select the DiSEqC mode from among either DiSEqC off or the DiSEqC 1.2 or 22 KHz tones before selecting the satellites.

If DiSEqC off is selected, the user can change the desired satellite using the ► (Next) button. After selecting the satellites from A to E, the KA-80 ACU changes the satellite when the user presses the ► (Next) button.

In the case of 22 KHz, firstly, the ACU commands the antenna to search for the 'SAT\_A' and then, if the ACU receives the 22 KHz tone via the 'receiver' port of the AUC back panel, the ACU commands the antenna to search for 'SAT\_B'. But this function requires the 22 KHz tone from the satellite TV receiver.

**NOTE:** If DiSEqC 1.2 is selected, the DiSEqC LED will turn on. Also, the satellite cannot be changed using the '► (Next)' button.

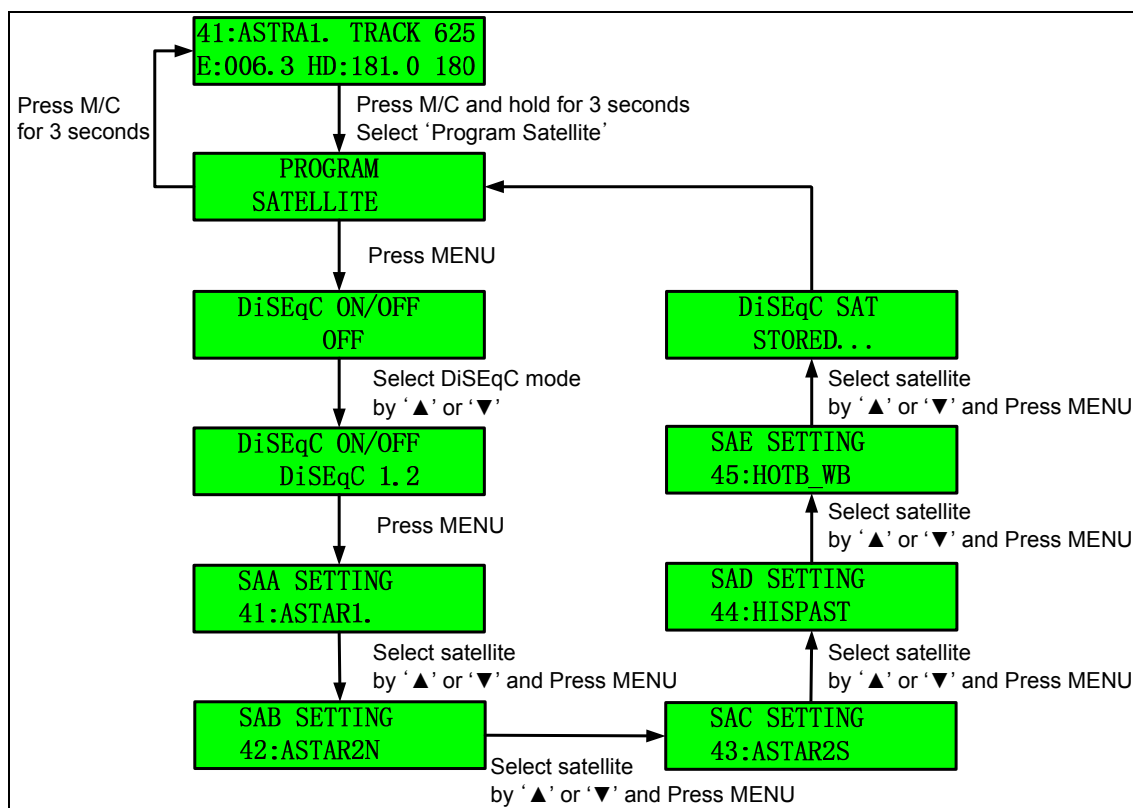

Figure 3-13 Program Satellite Setting Step

### Skew Angle Setting

The K5 calculates the skew angle automatically. However, if the user wants to change the skew angle, he/she can change the skew angle using the 'Manual Mode'. The user can also optimize the skew angle when desired satellite has polarity offset.

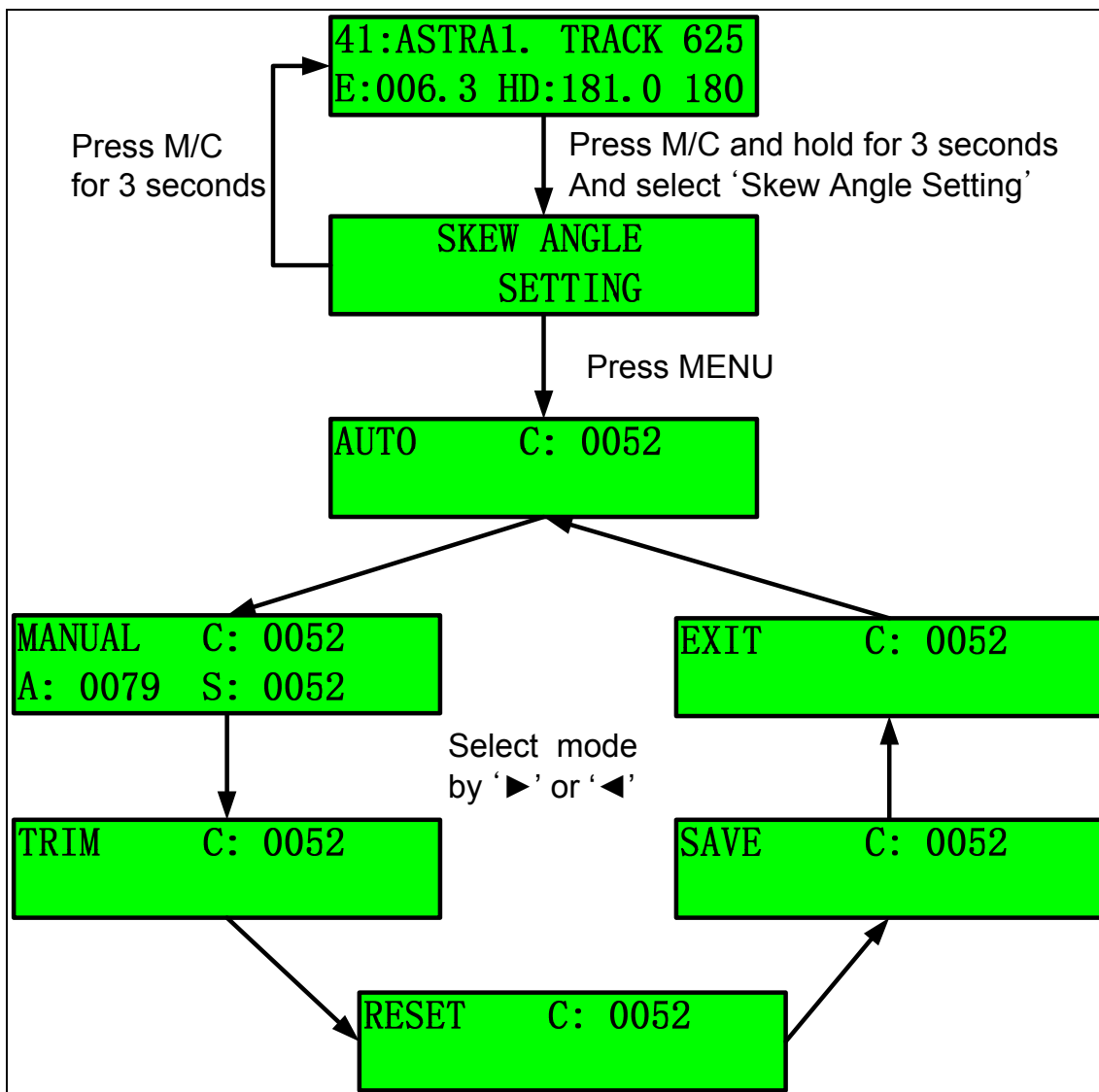

Figure 3-14 Setting the Skew Mode

**a. Auto Mode**

In the Auto mode, the ACU displays the skew angle calculated by the PCU. The K5's default skew mode is auto. The K5 automatically changes the skew angle when the satellite is changed.

**b. Manual Mode**

The Installer or Operator can change the skew angle to the desired skew angle, as shown below.

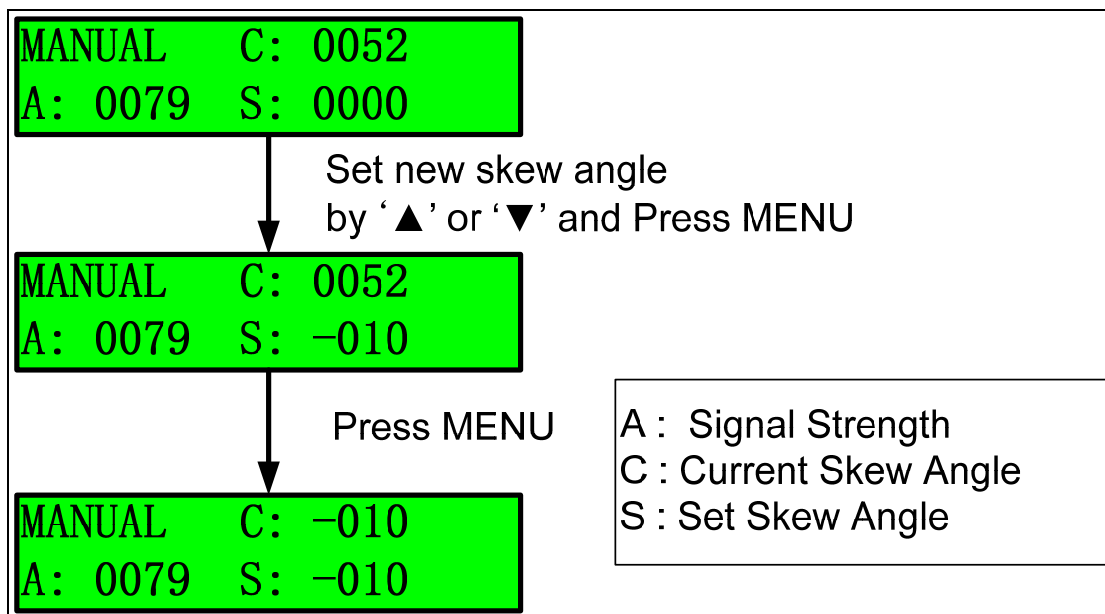

**Figure 3-15 Setting the Skew Angle in Manual Mode**

**NOTE:** 'C:' refers to the current skew angle. 'A:' refers to signal strength. 'S:' refers to the user setting the skew angle.

**c. Trim**

User can optimize the default skew angle to find a higher signal level, when desired satellite has polarity offset. First of all, change the skew angle where antenna can get higher signal than before using manual mode. And then select the 'TRIM' and press the 'MENU'. Lastly, select the 'SAVE' and press the 'MENU'. After save, the skew angle of desired satellite will be changed to new position.

**NOTE:** Polarity reference of satellite is the equator. However some satellite's polarity is other position not the equator for various reasons. And there is polarity offset between calculated skew angle by PCU and true skew angle on the satellite

that polarity reference is not the equator. Therefore installer and user should check whether there is polarity offset or not. If there is skew offset, skew angle should be changed to get a higher signal.

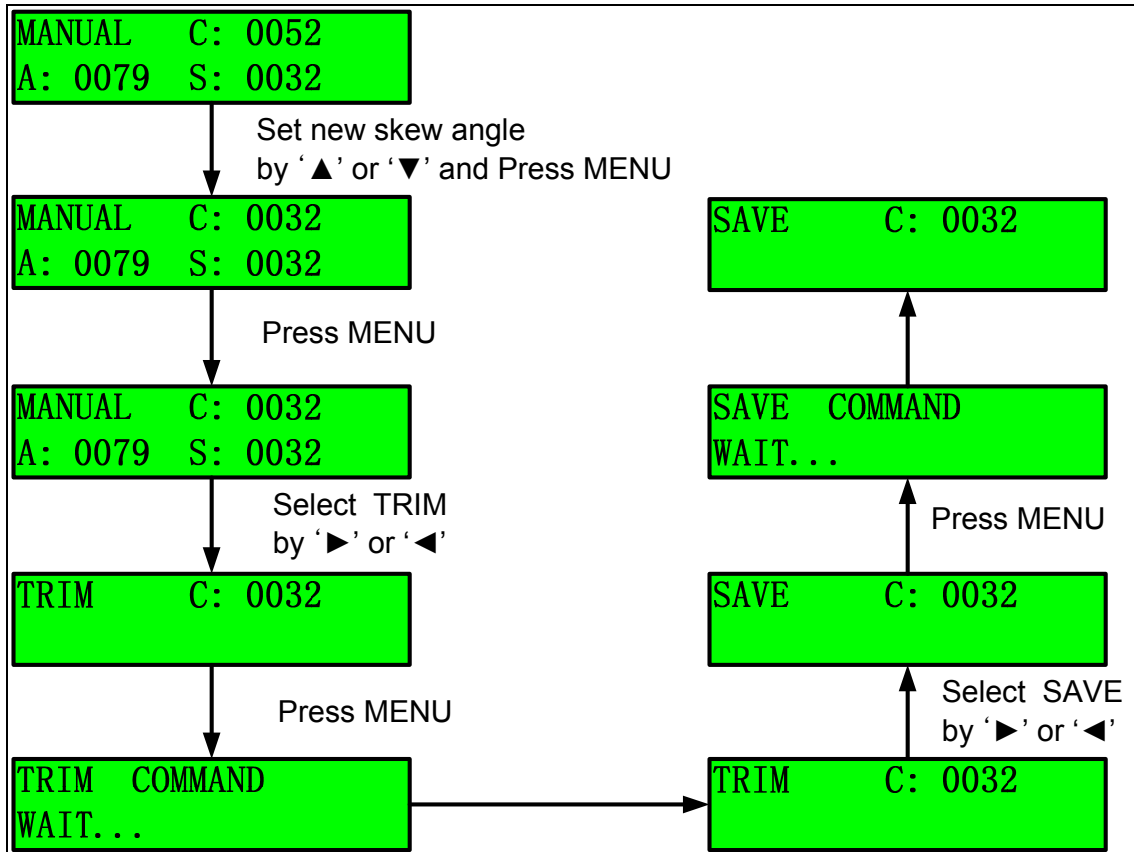

Figure 3-16 Steps of TRIM function

**d. Reset**

Reset is selected when it delete the inputted skew angle. The skew angle on desired satellite will be changed to initial skew angle after selecting the 'RESET' mode.

**e. Save**

Press 'MENU' after selecting the 'SAVE' mode, if you want to save the trim angle is saved.

**f. Exit**

Press 'EXIT' to escape to upper menu.



### Satellite Edit

Operator can edit the 5 satellites that be selected satellite on the 'SAA' to 'SAE'. If you select 'Satellite Edit', you can change the 5 satellites' name.

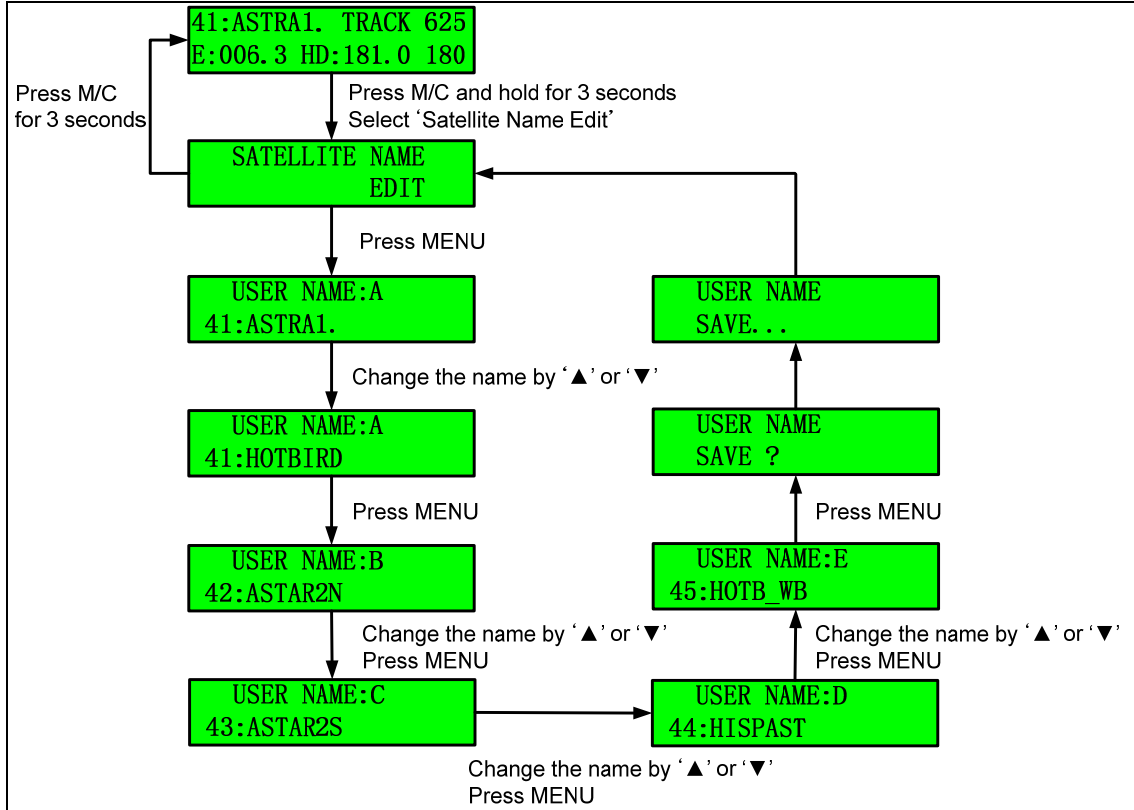

**Figure 3-17 Edit User-Settable Satellite Name**

## Satellite Parameter Edit

Operator can edit parameters like frequency and symbol rate, searching standard. This function is useful when desired transponder's parameters are no longer available.

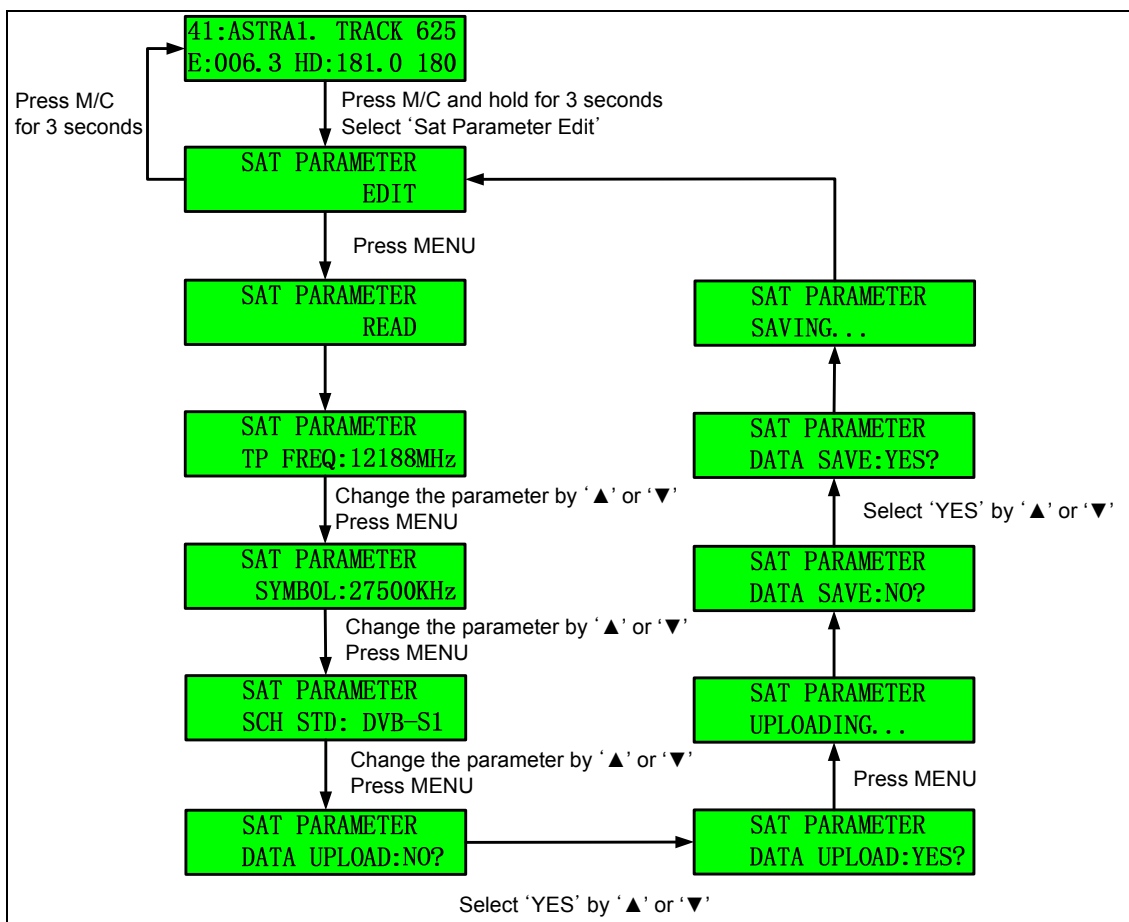

Figure 3-18 Edit the Satellite Parameters

## 4. How to Operate SCS

Installer or operator can change parameters by SCS(SuperTrack Control Software) Version 1.8.1. Also SCS can show the current status of K5.

### 4.1. Connect to PC

After connects to the PC like Figure 3-8, runs the SCS. Press M/C and hold 3 seconds or select 'Upgrade' in setup mode.

And then select the COM port of your computer, select baud rate 19200. Lastly click the 'DISCONNECT', then K5 is connected with computer.

You can see that 'CONNECT' LED of status panel is on like Figure 4-2. Also, you can see the current display of ACU LCD. State of antenna is one among 'Initialize', 'Searching' 'Searching Fail', and 'Tracking', 'HALT'.

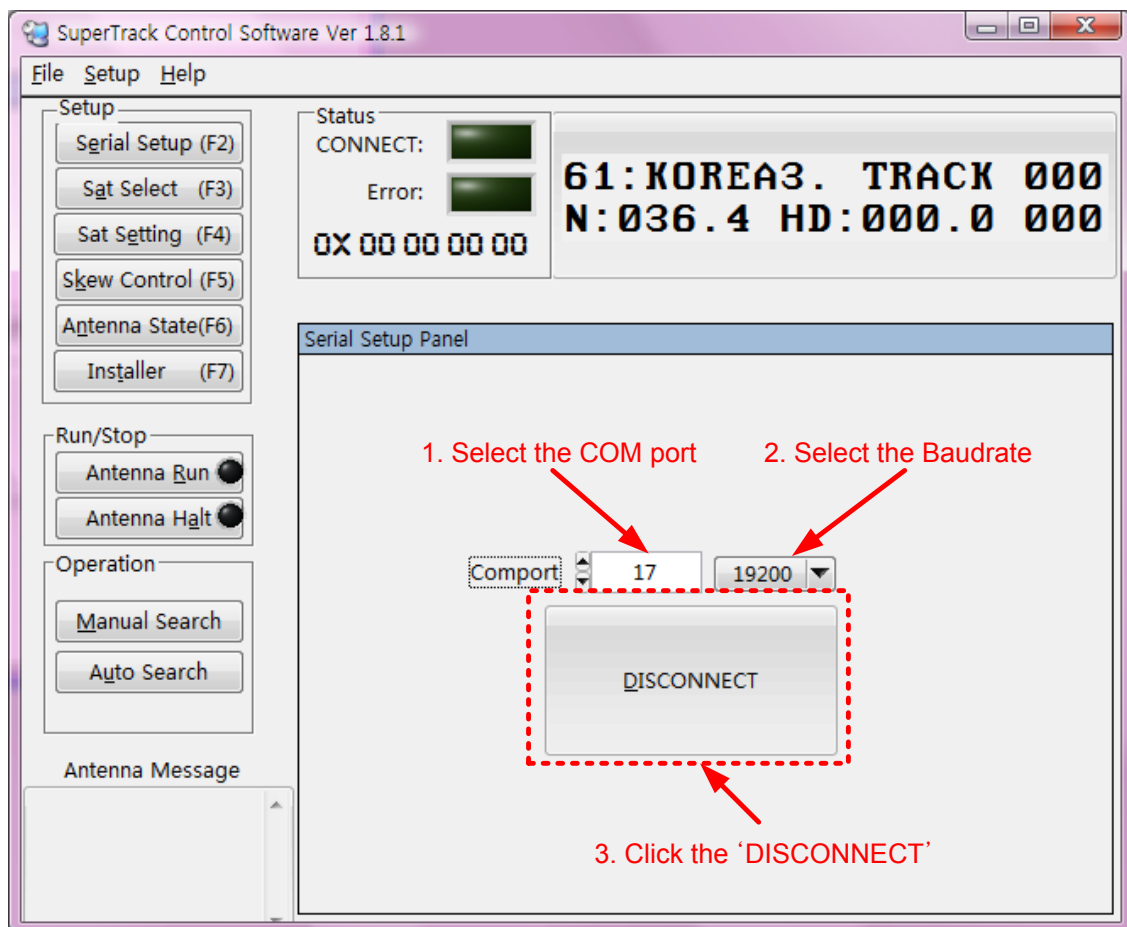

Figure 4-1 Connection K5 with PC

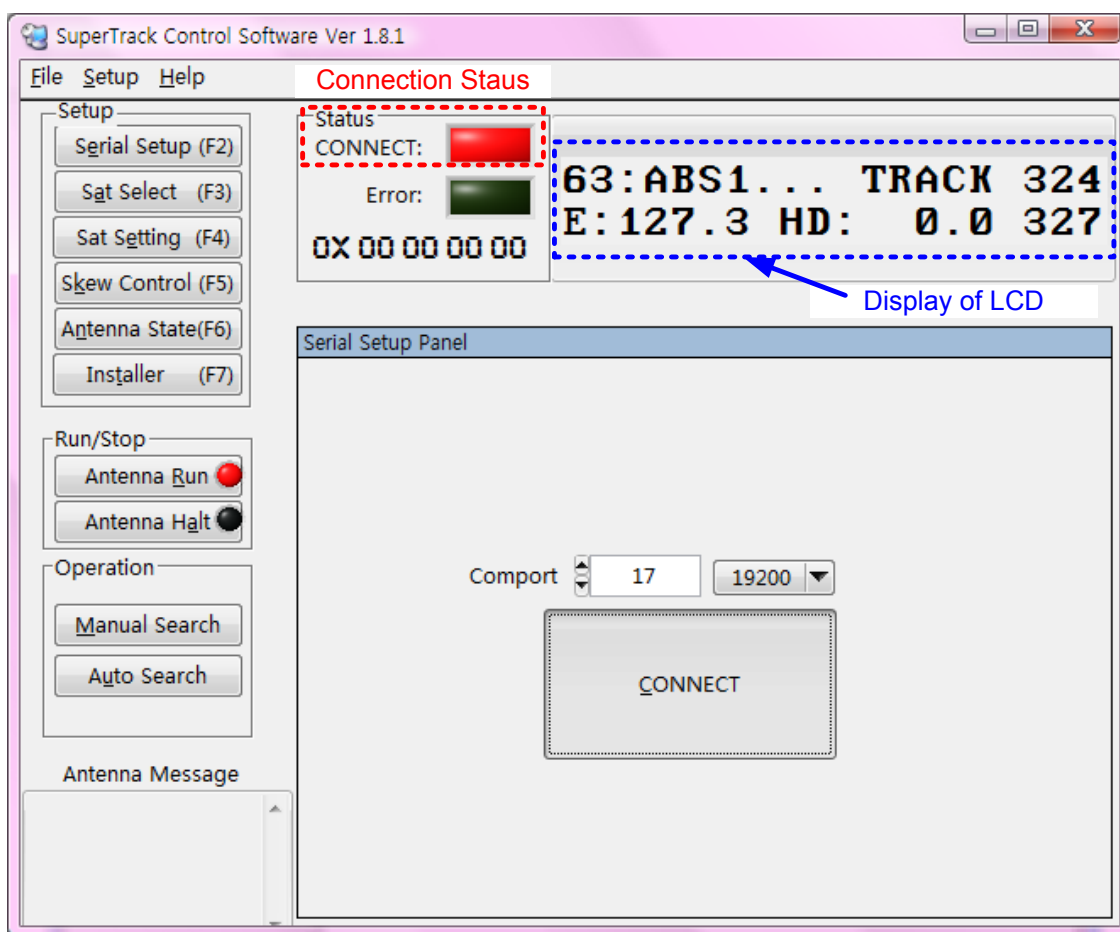

Figure 4-2 Connection Status K5 with PC

## 4.2. Setting the parameters of the satellite

### Satellite Select

You can select area and satellite by SCS. Refer to below step and Figure 4-3.

- a. Click the 'Sat Select(F3)' or press F3.
- b. Select area in 'Zone Select'.
- c. Select desired satellite in 'Satellite Select'.
- d. Press 'Send' to upload to PCU.

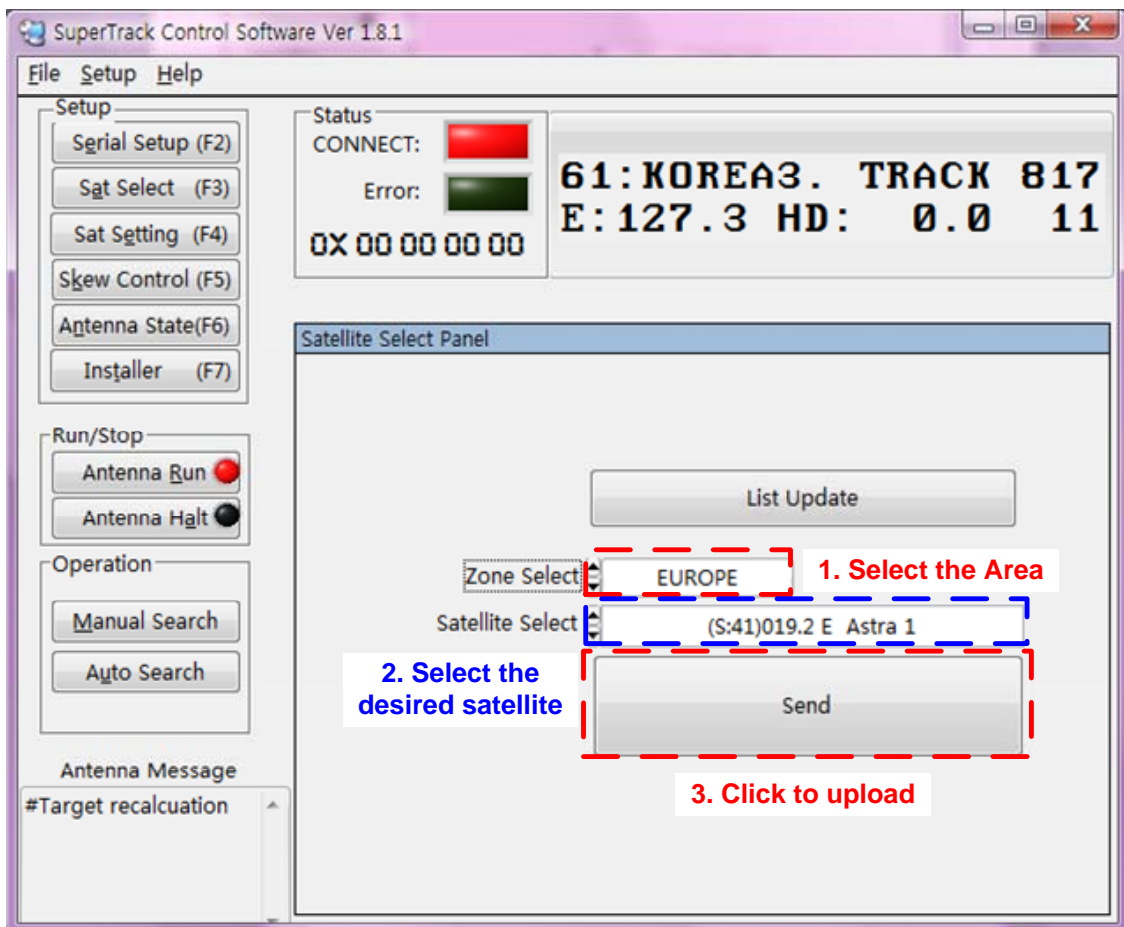

Figure 4-3 Select Area and Satellite Step

**NOTE:** K5 has 4 areas(Europe, Asia, North America, and South America). K5 has parameters of 80 satellites; there are 20 satellites on each area.

## Satellite List Update

You can modify the satellite name and longitude in SCS. SCS program folder(\Program Files\SuperTrackV3\_3) has on text file. The text file's name is SatIDMatch. If you want change the satellite name or longitude, you can modify this text file and click the 'List Update', select the changed text file. Then satellite name or longitude is changed in satellite list. But changed satellite is only changed the display name and longitude on the SCS. If you want to change the satellite parameters, you have to change the satellite parameters in 'Sat Setting(F4)'.

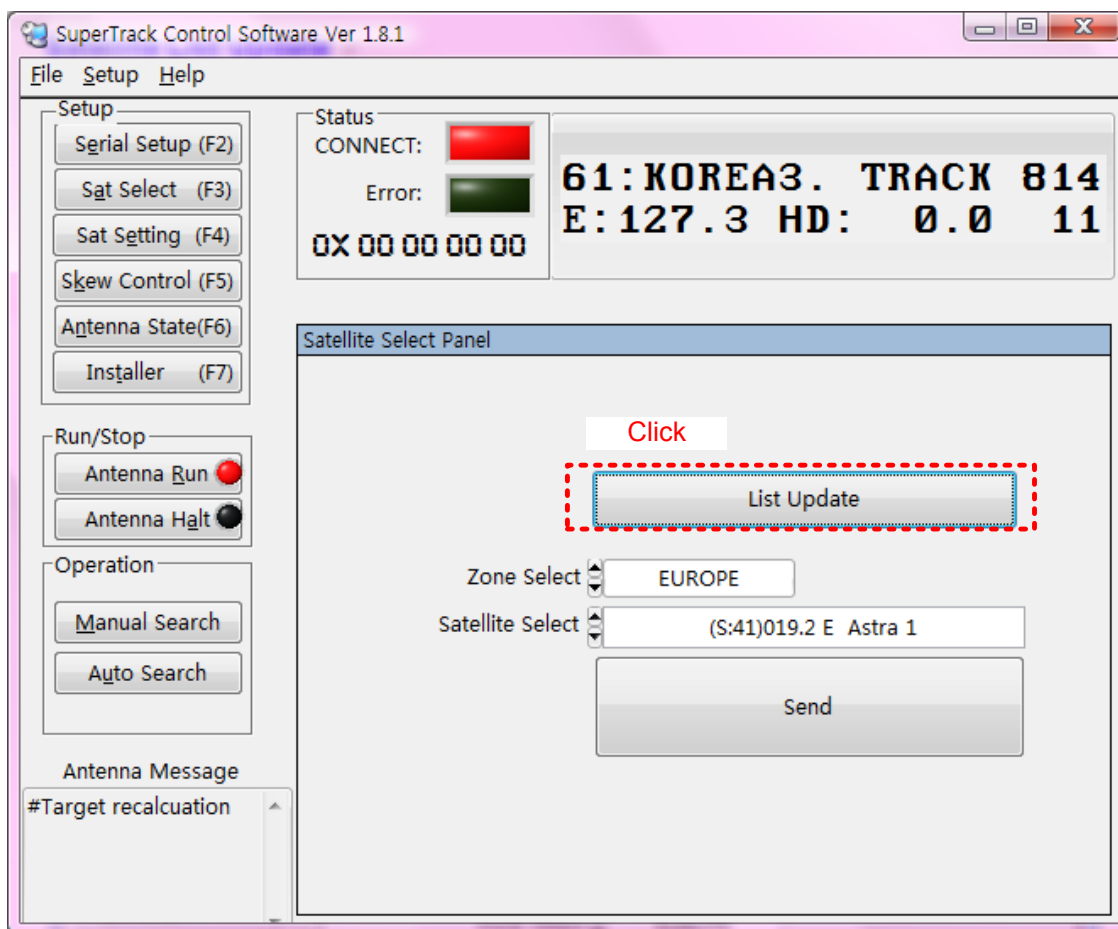
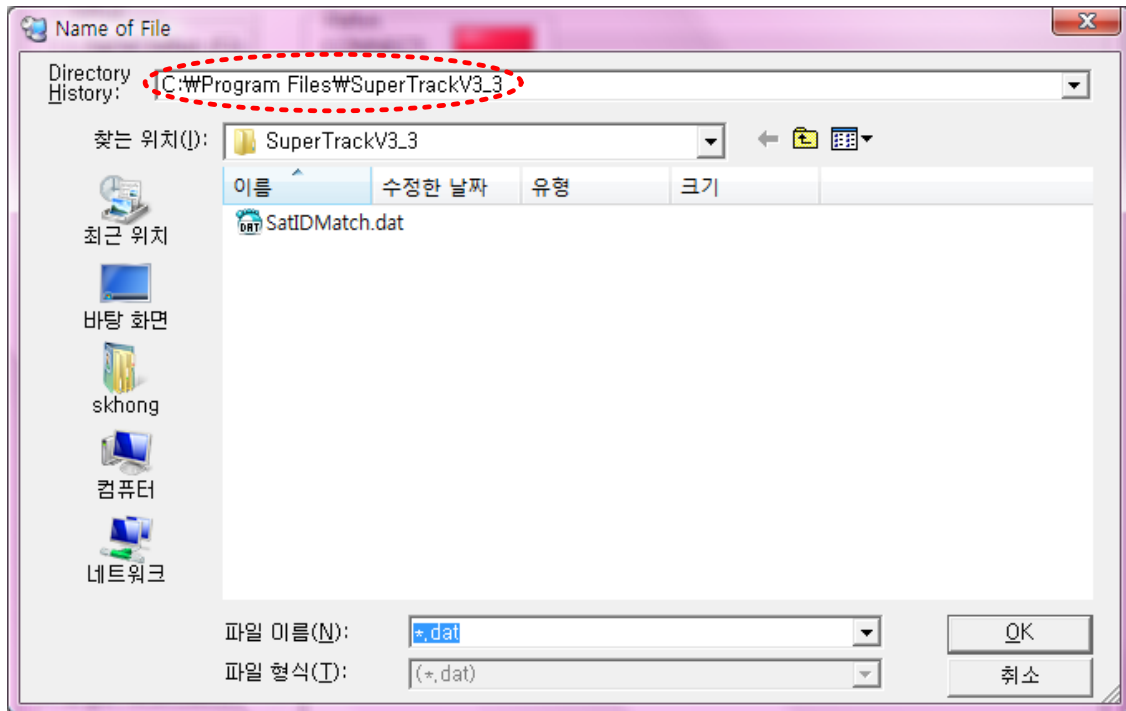

Figure 4-4 Satellite List Update Step 1

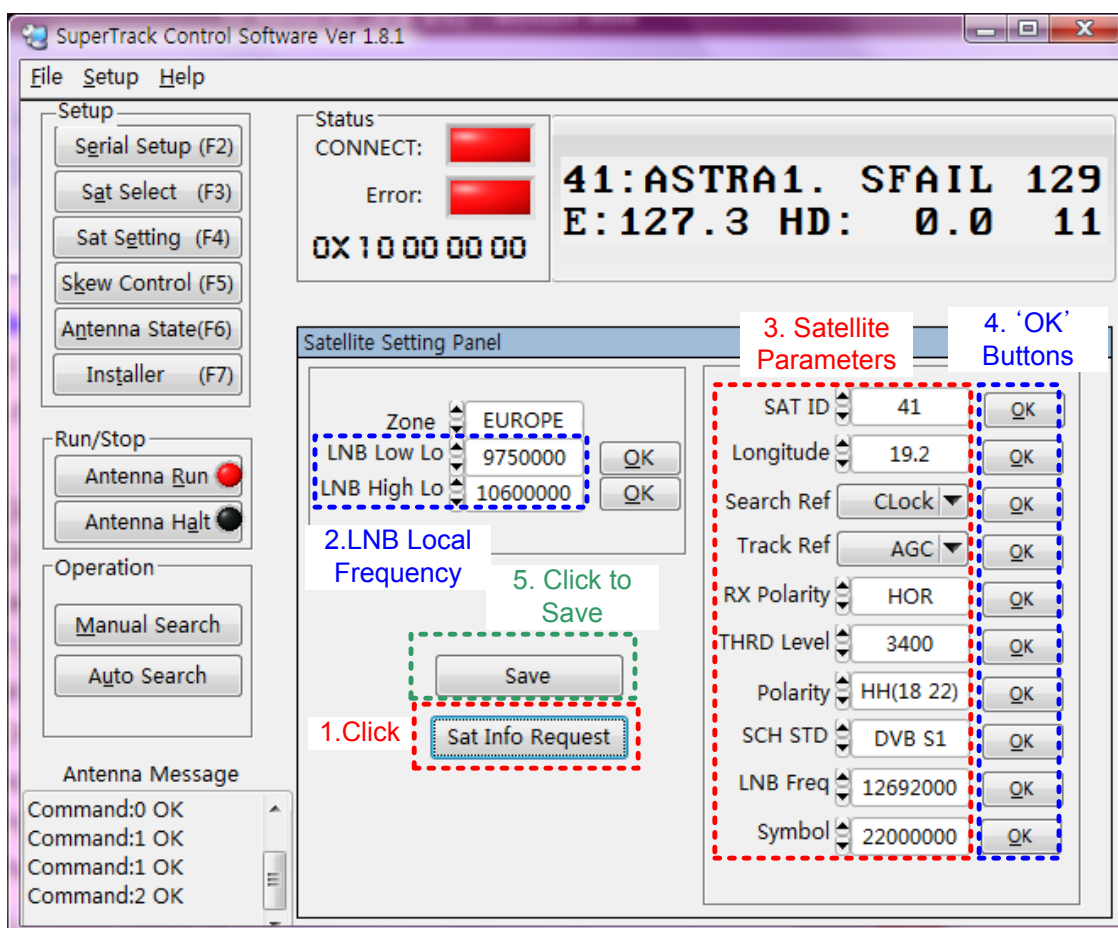

**Figure 4-5 Satellite List Update Step 2**

## Edit Satellite Parameters

If select user settable satellite or desired satellite's parameters are not correct, you can change the select satellite's parameters. Refer to below step and Figure 4-6.

- Click the 'Sat Setting(F4)' or press F4 after select the desired satellite.
- Click the 'Sat Info Request' to update from PCU. Then target satellite's parameters are uploading to parameters panel from PCU.
- If you want to change the LNB local frequency, input the new local frequency and click the 'OK' button to upload to PCU.
- Change the satellite parameter and click each 'OK' button to upload to PCU. (If not click after change the parameters, changed parameters are not upload to PCU)
- Press 'Save' to save changed parameters.



**Figure 4-6 Edit Satellite Parameters**

**NOTE:** LNB local frequency is same in same area.

**NOTE:** Should click the 'Save' to save the changed parameters to PCU.



SAT ID means satellite index like below.

- ID 1~20: North America
- ID 21~40: South America
- ID 41~60: Europe
- ID 61~80: Asia

**NOTE:** There are no some satellites on the satellite list of SCS. However you can select other satellites as below method.

- a. Input the SAT ID(1~80), and click the 'OK'.
- b. Click the 'Sat Info Request', and then the parameters of desired SAT ID will be uploading to parameter panel.

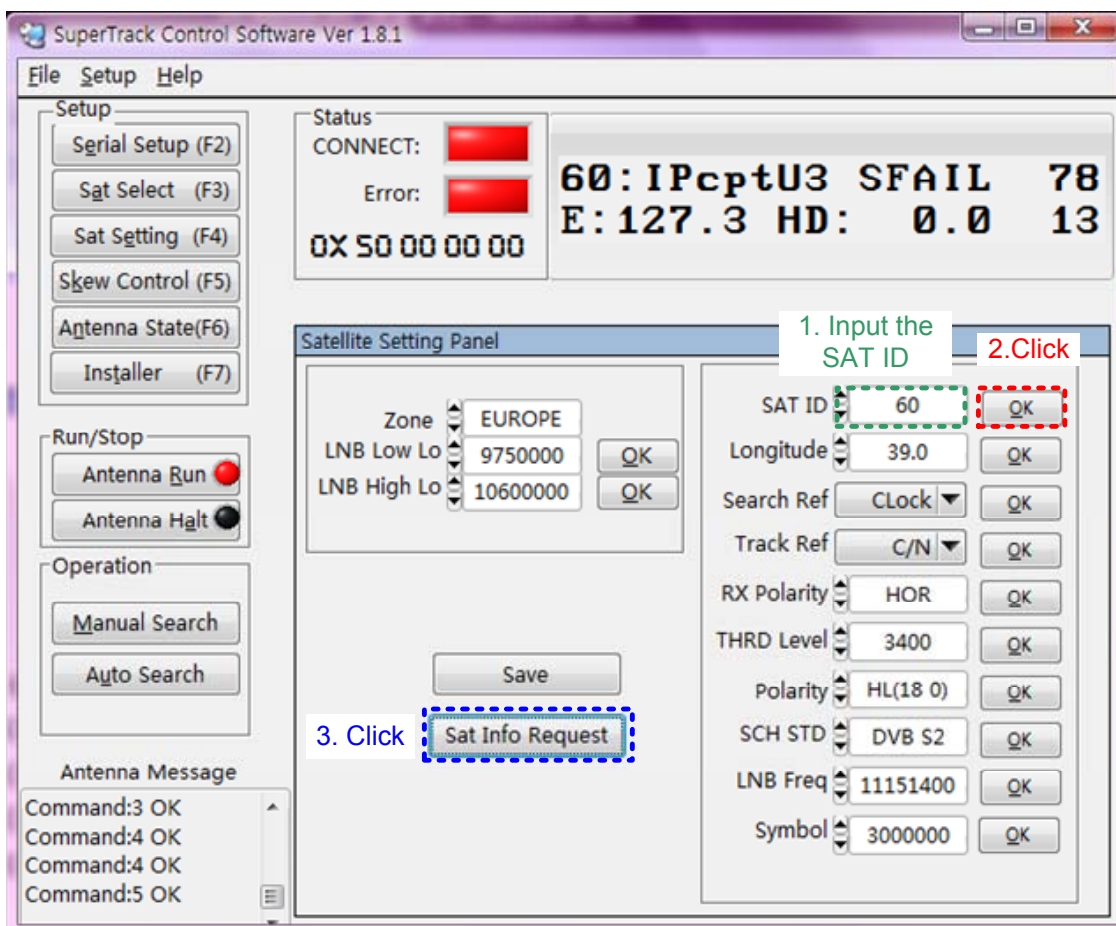

**Figure 4-7 Edit Satellite Parameters**

Search Ref means K5's searching reference that used reference during the search the satellite.

AGC THD: Search higher AGC level than preset AGC threshold level in PCU.

C/N THD: Search higher C/N level than preset C/N threshold level in PCU.

CLock: Search the target DVB Carrier lock(**Default**).

Track Ref means K5's tracking reference that used reference during the track the satellite.

AGC: Track the highest AGC level(**Default**).

C/N: Track the highest C/N level.

RSSD(Receive Signal Detector): Track the highest RSSD value(It is currently not available).

RX Polarity means RX polarity of satellite.

Horizontal/Vertical

THRD Level means threshold level if searching reference is AGC THD or C/N THD.

Polarity means voltage and tone of LNB. K5's default is 'HH'

Linear LNB(Horizontal/Vertical, High/Low)

HH(18V, 22KHz)

HL(18V, 0KHz)

VH(13V, 22KHz)

VL(13V, 0KHz)

Circular LNB(Left Handed/Right Handed, High/Low)

LH(18V, 22KHz)

LL(18V, 0KHz)

RH(13V, 22KHz)

RL(13V, 0KHz)

SCH STD means Searching standard.

Auto: PCU automatically search the carrier.

DVB S1: search the DVB S1 carrier.

DVB S2: Search the DVB S2 carrier.

DSS(Digital Satellite System): US standard

LNB Freq means RX frequency of satellite.

Symbol means symbol rate of satellite.

**NOTE:** In case of tracking reference is AGC, adjacent satellite's carrier can affect desired satellite's carrier as below Figure 4-8. Some satellites have the adjacent satellite interferences the same reason as above. So should set the tracking reference to 'C/N' in these satellites.

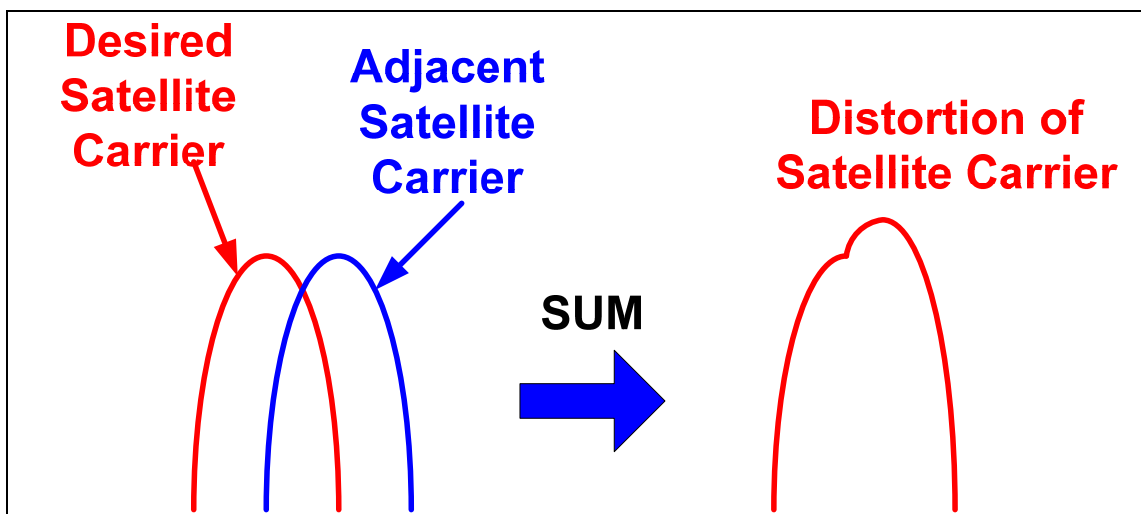

**Figure 4-8 Affection of neighborhood satellite**

**NOTE:** If select the 'Auto' in 'SCH STD', K5's searching time is slower than select the 'DVB S1' or 'DVB S2'.

### 4.3. Skew Control

You can select skew mode ('Auto' or 'Manual') by SCS. Also change the skew angle at desired skew angle using 'Manual' mode.

#### Change the skew angle on manual mode

- Input the desired skew angle in 'Desired Manual Angle'.
- Click the 'Skew Manual', then skew move to desired angle.

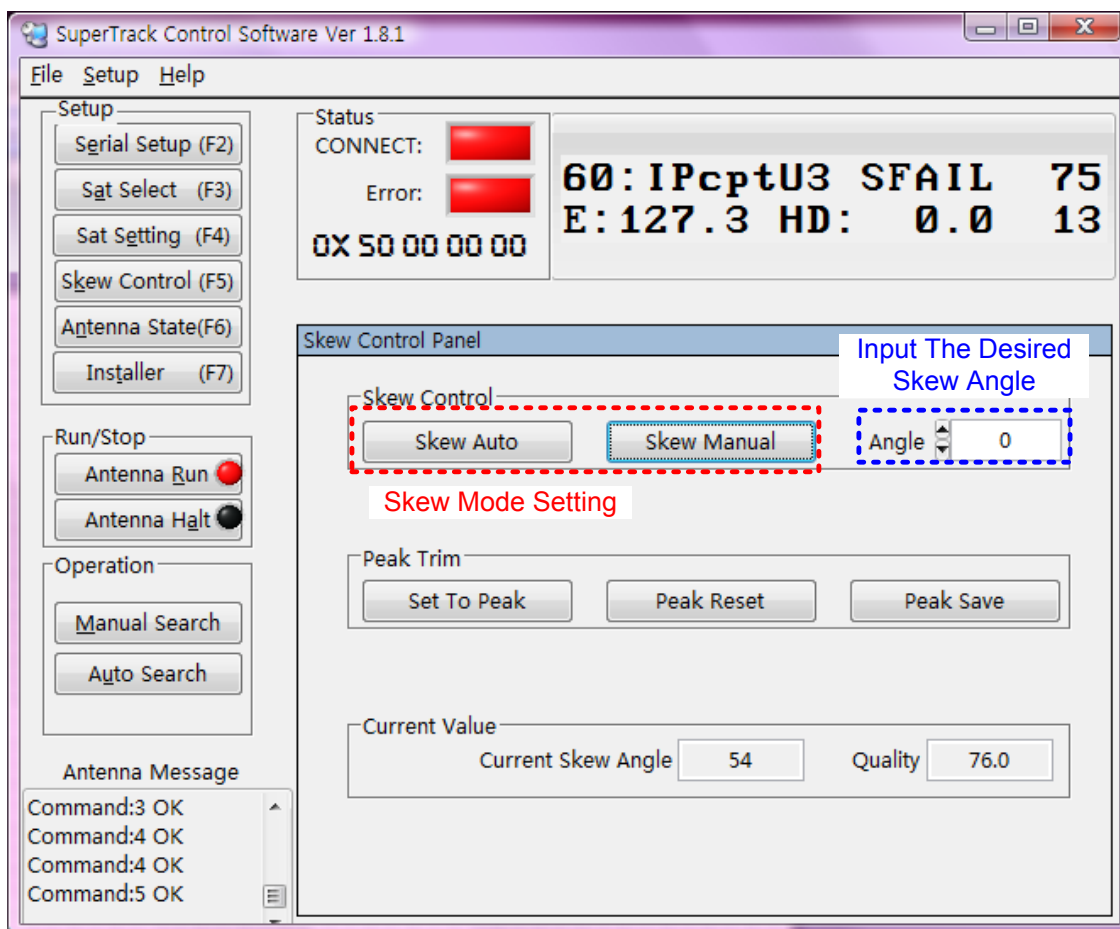

**Figure 4-9 Change the Skew Angle on Manual Mode**

**NOTE:** In case of K5's skew is manual mode, K5's skew is not changed when switch the satellite or change the vessel position(longitude, latitude).

## Set the peak trim

Skew angle automatically calculated by PCU, but sometimes satellite has skew offset. In this case, you have to set the peak to track a higher quality. Refer to below step and Figure 4-10. This function is same with 'TRIM' on the ACU.

- Change the skew angle on skew manual mode after select the desired satellite that has skew offset.
- Look at the Quality, then search higher quality by change of skew.
- Click the 'Set To Peak', after search a higher quality.
- Click the "Peak Save" to save changed peak.
- Then, K5's skew is moving to changed skew angle when select this satellite.

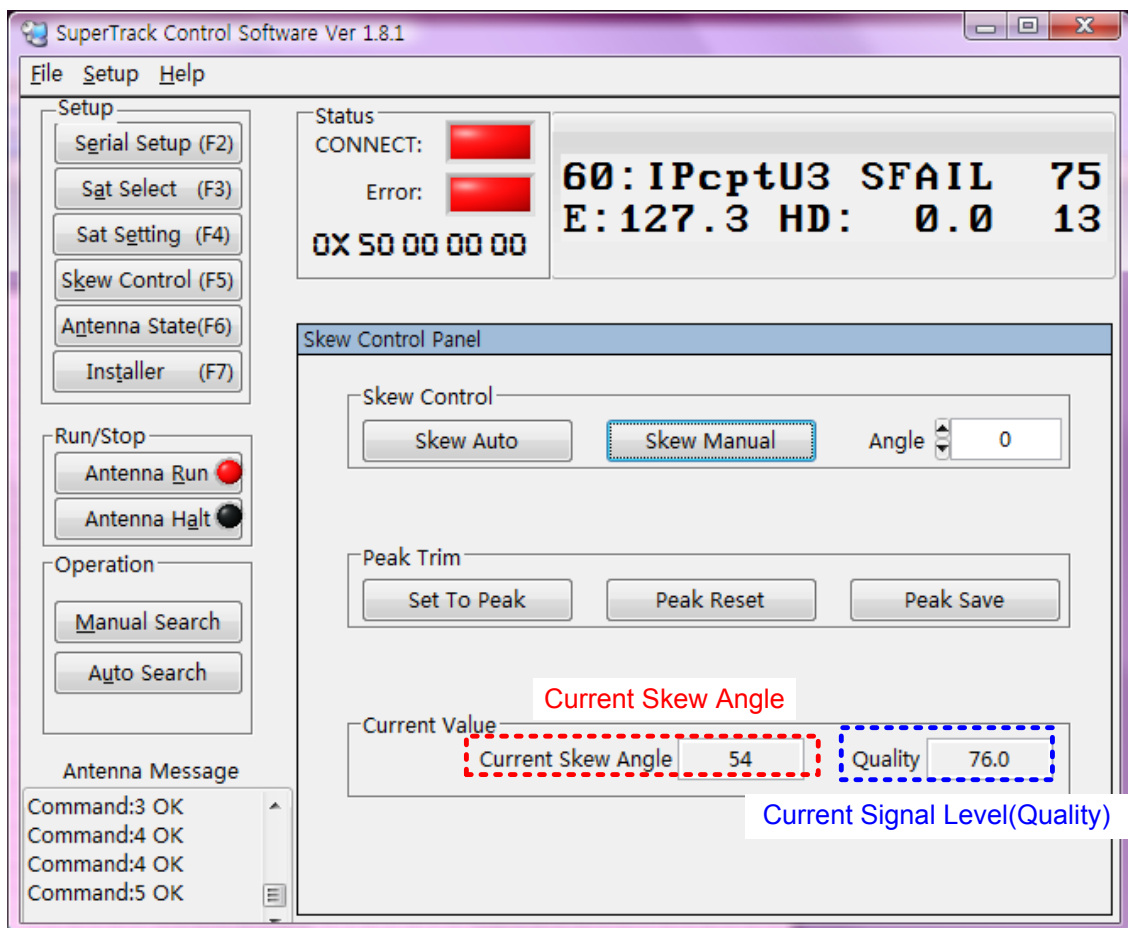

**Figure 4-10 Setting Peak Trim**

**NOTE:** If you want reset the peak, click the 'Peak Reset' and click the 'Peak Save'.

## 4.4. Antenna State

You can see the current state of K5 by SCS like below. Click the 'Antenna State' or press F6.

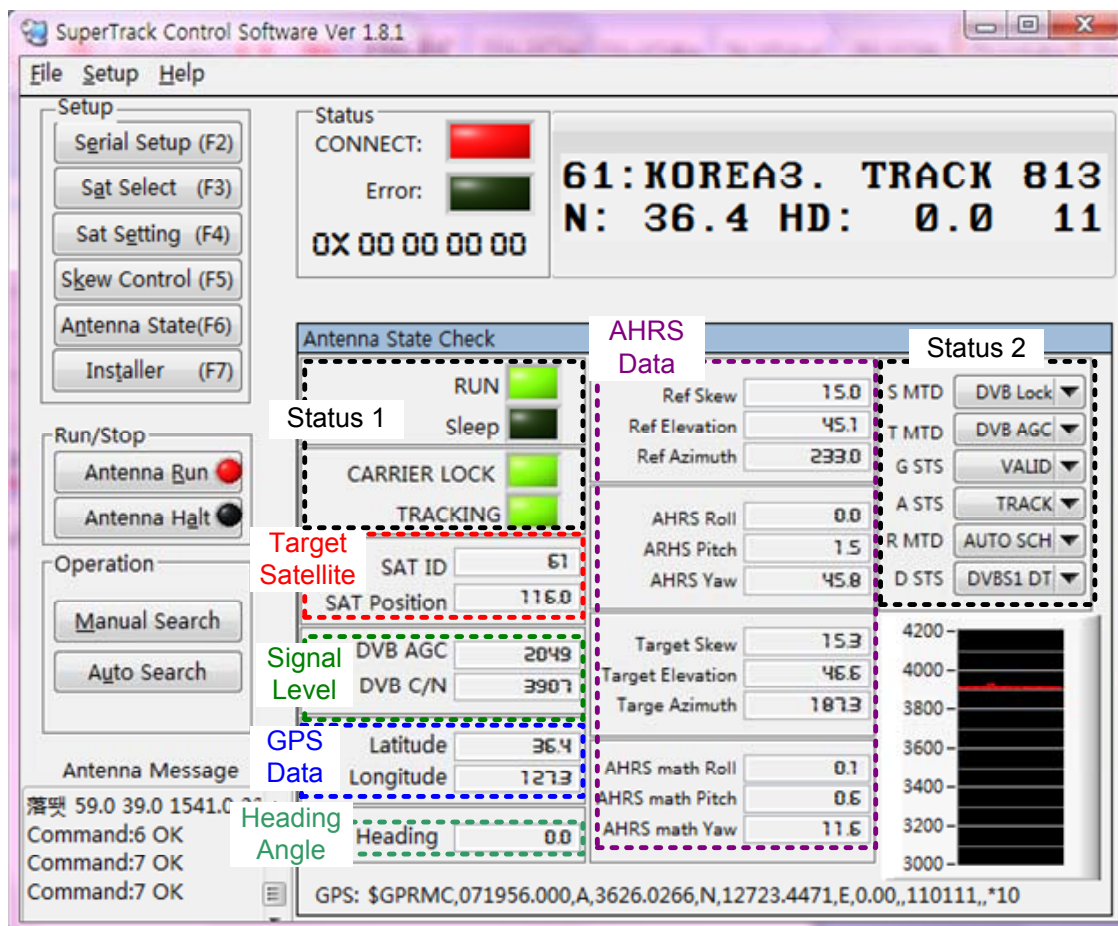

Figure 4-11 Antenna State

### Current Status of antenna

User can check the status of antenna, which are status of run and sleep, carrier lock, tracking and searching and tracking reference, GPS state, searching standard, searching method.

### Target Satellite

User can look at the SAT ID and longitude of target satellite.

### Signal Level

User can see the signal level of target satellite as AGC and C/N when antenna is tracking the satellite. In case of satellite with weak signal, AGC is about 1700 and C/N is about 3500. Also in normal signal level, AGC is about 1800 and C/N is

about 3600. However these values can be changed by a weather condition or other reasons.

### GPS Data

User can check the current GPS data.

### Heading Angle

SCS displays the ship's heading angle when ACU accepts the NMEA signal from ship's gyro via NMEA port.

### AHRS Data

K5 has IMU(Inertial Measurement Unit) to measure the roll and pitch, yaw angle. These values are used to search for and track the satellite. Also skew angle is automatically changing using these values when vessel is rolling.

AHRS math roll and pitch, yaw are calculated by inverse kinematics when antenna is tracking the satellite. Also this AHRS math yaw angle is displayed on the ACU when antenna is tracking the satellite as below. This value is reliable to use the heading angel of vessel when gyro compass is broken.

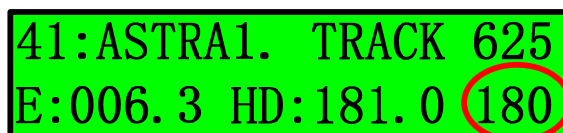

41:ASTRA1. TRACK 625  
E:006.3 HD:181.0 180

Figure 4-12 AHRS math yaw

## C/N Graph

You can see the graph of C/N on 'Antenna State'.

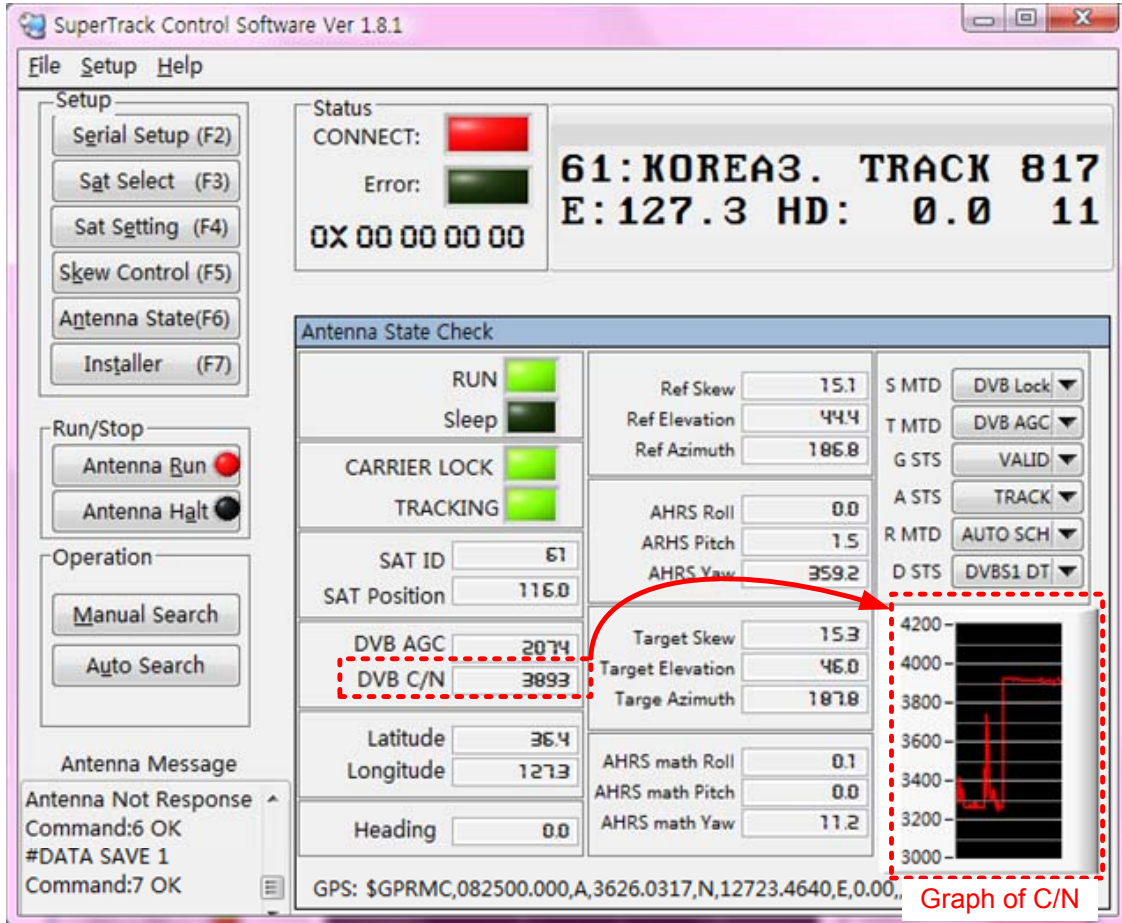

Figure 4-13 C/N Graph



## 4.5. Installer

Installer and operator can monitor the status of antenna using installer panel. Also they can select the searching mode, which are manual pointing and manual searching, auto searching. And can set the skew trim. Click the 'Installer' or press F7.

**NOTE:** After change the skew trim angle and reset the skew trim angle, you must click the 'SAVE' to save to PCU.

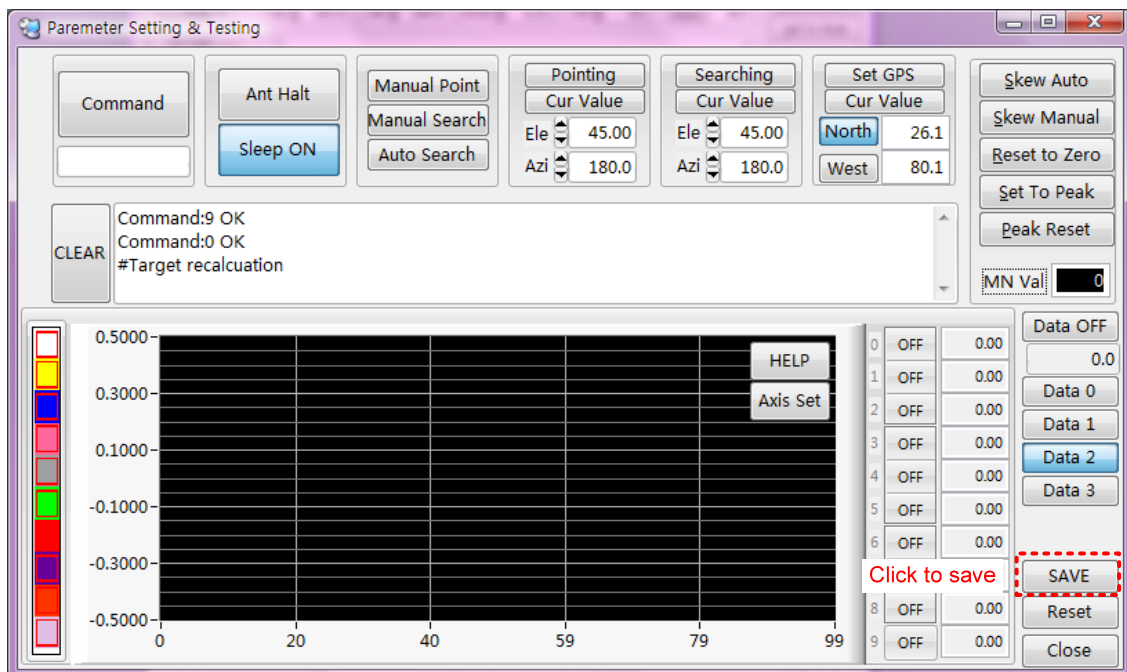

**Figure 4-14 Saving the Initial Value**

## Skew Setting

Method of skew trim is same with 'Skew Control(F5)' panel.

## Set GPS

SCS is set the GPS data, when GPS data is not valid or breakdown.

- a. Input the latitude and longitude.
- b. If change the 'North' or 'South' and 'East' or 'West', click the 'North' or 'South' and 'East' or 'West'
- c. Click the 'Set GPS'

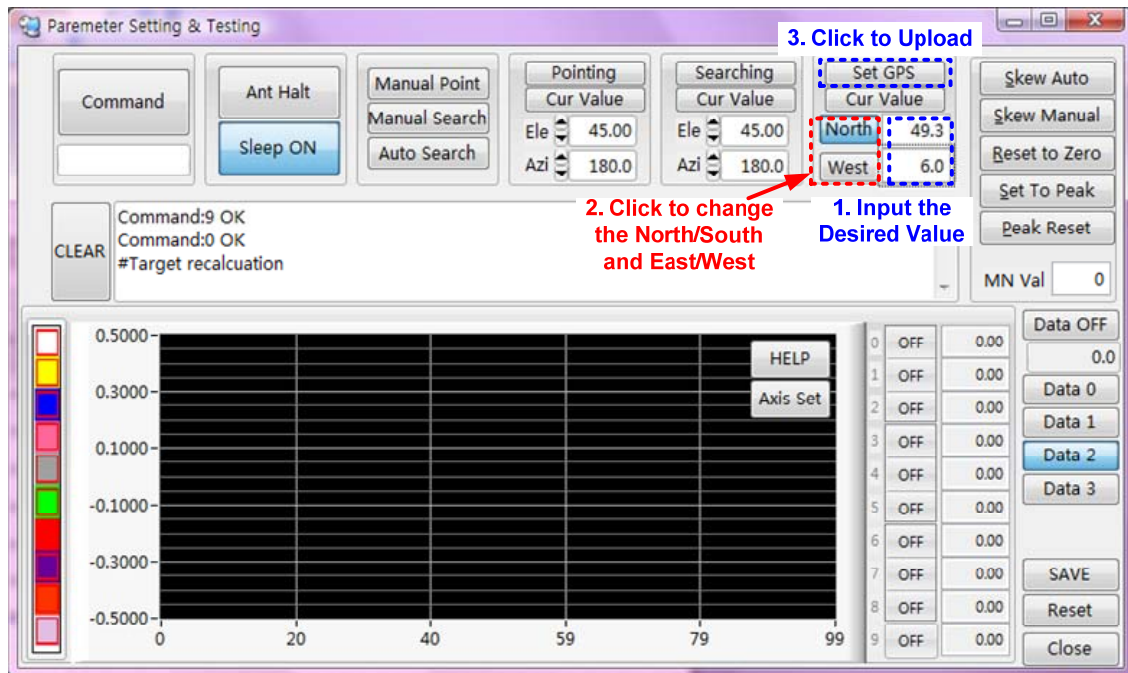

**Figure 4-15 Setting the GPS Data**

**NOTE:** If click the 'Cur Value', current GPS data is displayed in GSP panel when GPS is available.

## Manual Pointing

Antenna is pointing toward desired position where is inputted by user. Antenna realizes the 'BOW' mark on the Radome base when ACU is not connected with ship's gyro.

- Press the 'Manual Point' to stop the searching.
- Input the desired elevation and azimuth angle.
- Press the 'Pointing' to move to desired position.

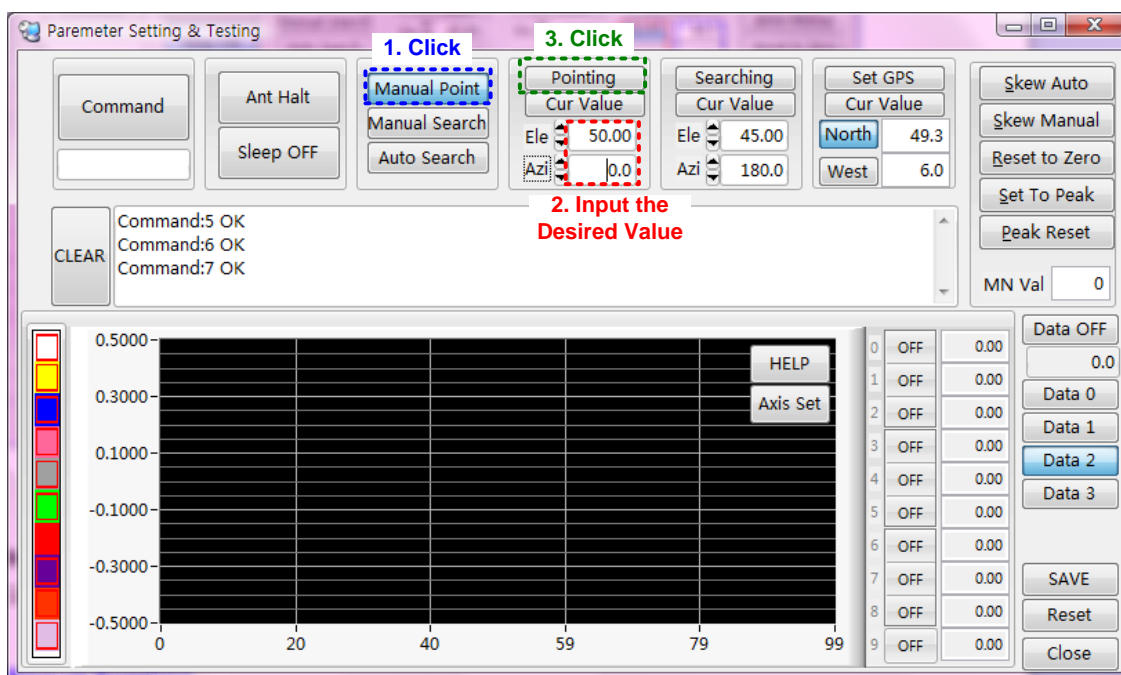

**Figure 4-16 Manual Pointing**

## Manual Searching

Antenna starts the searching from desired position where is inputted by user.

- Press the 'Manual Search' to stop the searching.
- Input the desired elevation and azimuth angle.
- Press the 'Searching' to move to desired position.

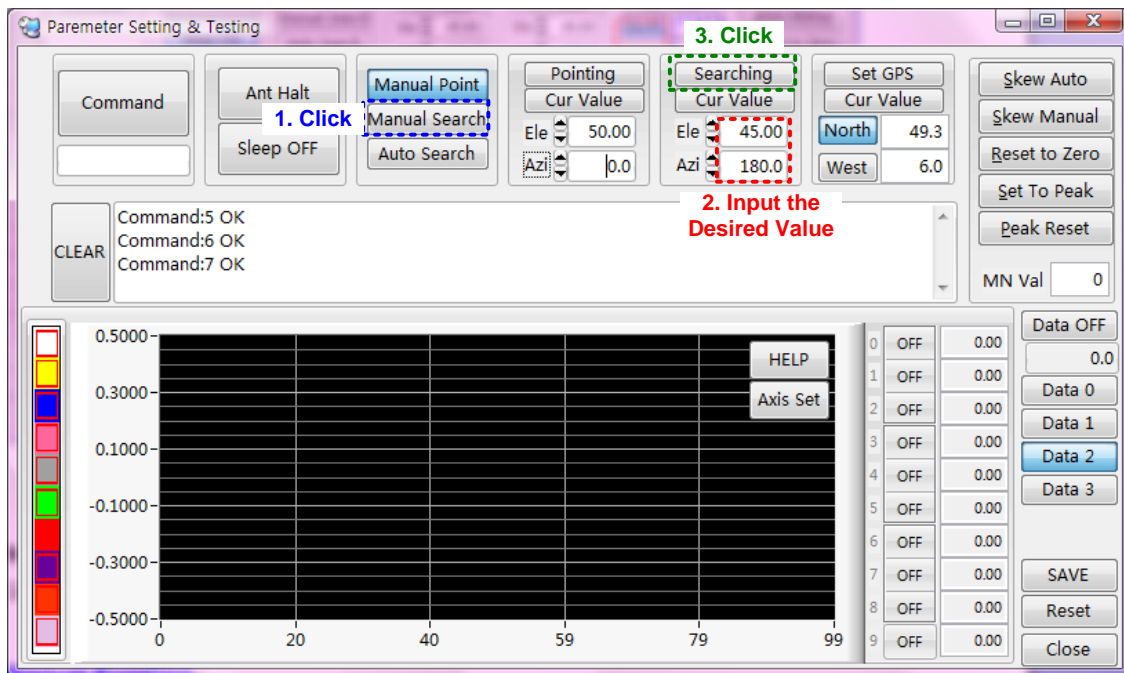
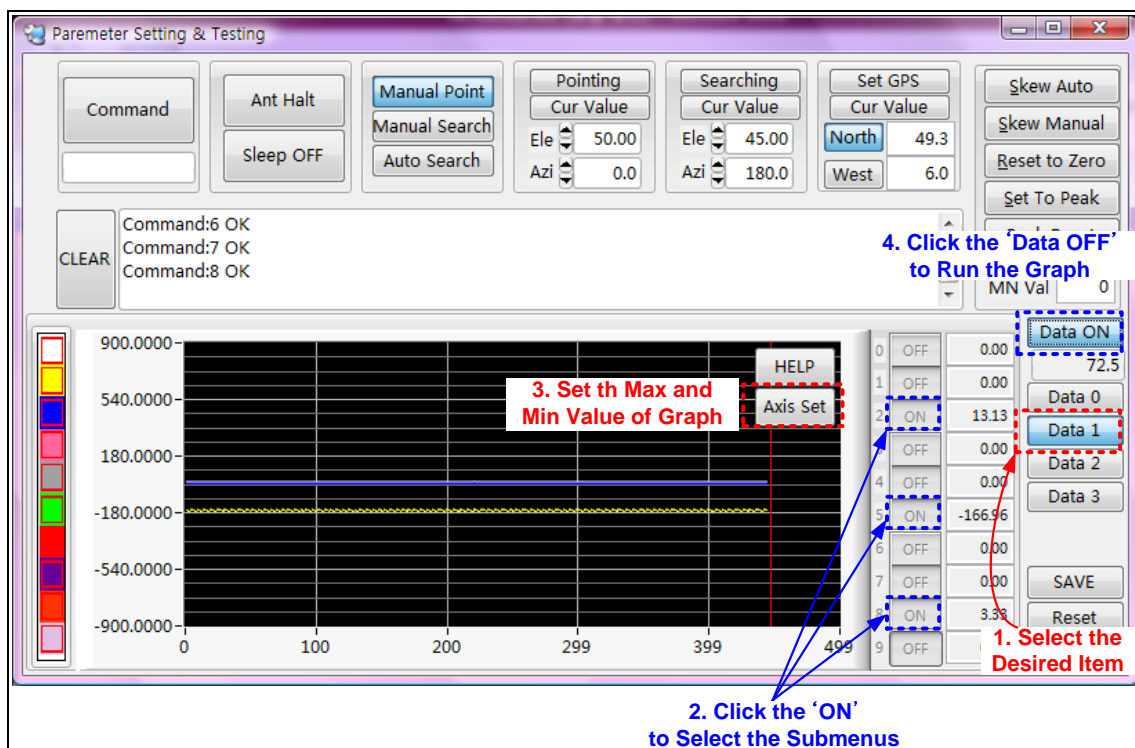

Figure 4-17 Manual Searching

## Graph

You can see the antenna parameters graph by SCS. Refer to below step.

- Select item('Reference', 'CurSate', 'Error', 'Voltage'),
- Select sub menus (1~9), then click the 'on' button of selected submenus.
- Click the "Axis Set" to set the axis set, then change maximum and minimum value of graph.
- Click the 'Data OFF' to see the graph.
- Click the 'Data ON' to stop the graph.



**Figure 4-18 Graph View**

**NOTE:** Click the 'HELP' button, then you can see the index of graph.

## Appendix A: Example of Setting the Satellite's Parameters Using SCS

The K5 has 80 satellite parameters. You can input or change the satellite parameters if there is no desired satellite.

If you want to input the desired satellite parameters in User 1, please follow the steps outlined below.

Satellite	Longitude	RF Frequency	Symbol Rate	Polarity
Astra1	E19.2	12,692MHz	22,000KHz	Horizontal

Table A-1 Default Satellite Parameters in Astra1(Sat ID : 41)

Satellite	Longitude	RF Frequency	Symbol Rate	Polarity
Astra1	E19.2	12,266MHz	27,500KHz	Horizontal

Table A-2 Desired Satellite Parameters

Connect ACU with PC and press and hold 2~3 seconds the 'M/C' of ACU front panel

Run the SCS Ver. 1.8.1

Click the 'DISCONNECT'

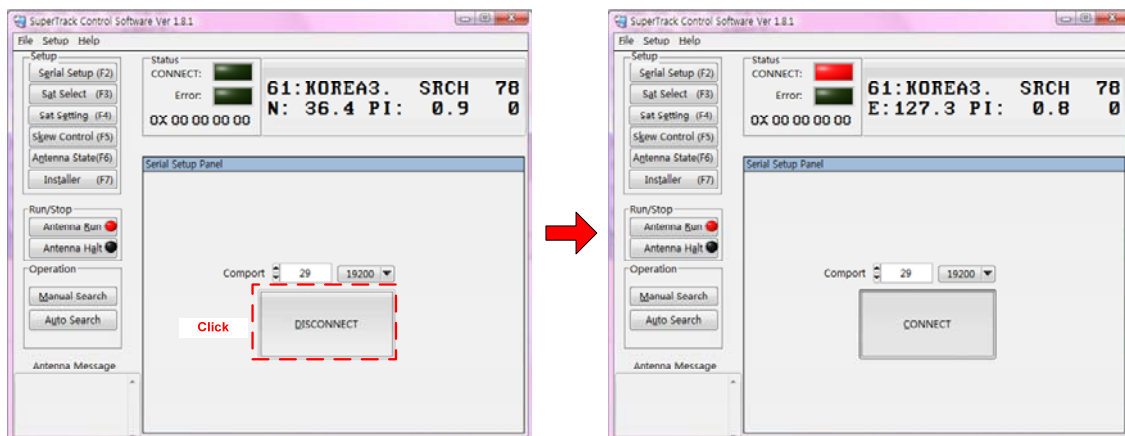

Click the 'Sat Select' or press 'F3'

Select the 'EUROPE' in 'Zone Select'

Select the '(S:58)023.5E Astra2ConLow/User1' in 'Satellite Select'

Click the 'Send' to upload to PCU.

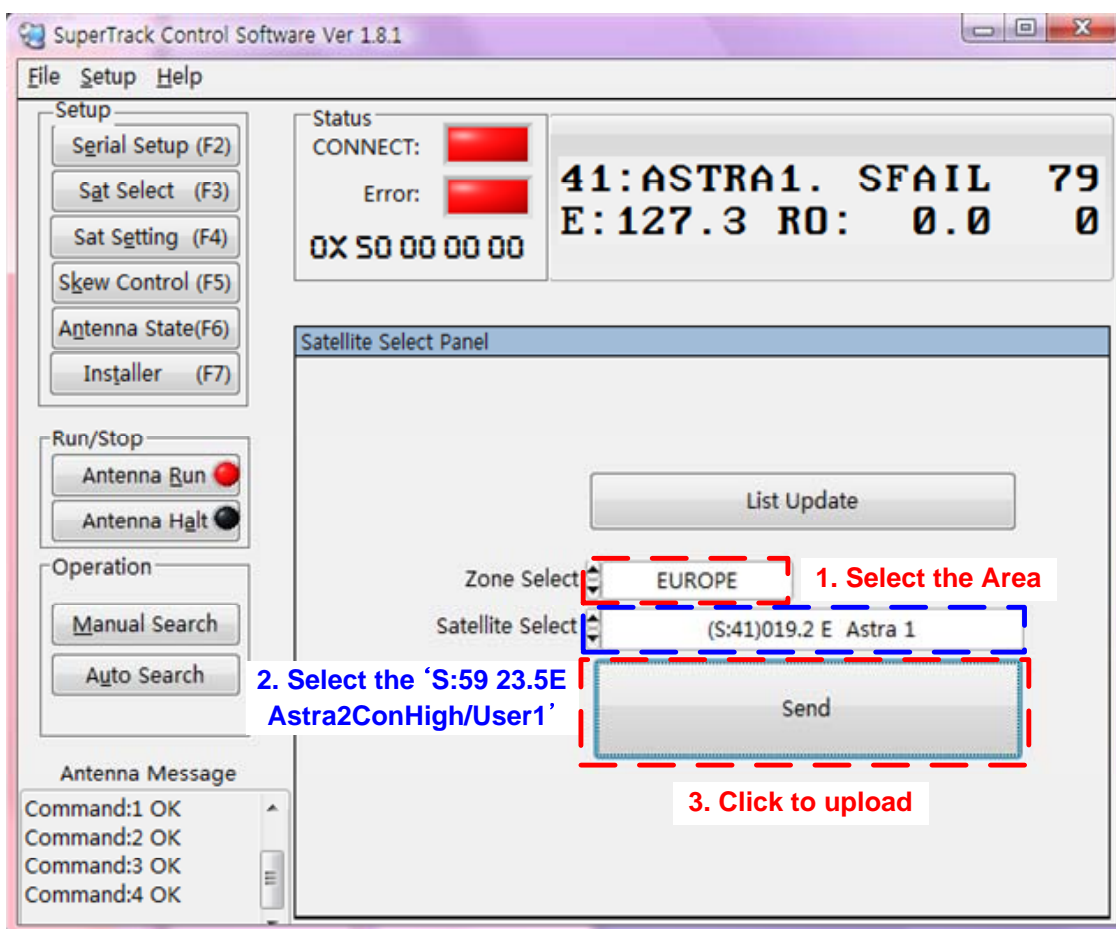

Click the 'Sat Setting' or press the 'F4'

Click the 'Sat Info Request' to request the desired satellite's parameters, then sat ID 59 satellite's parameters is updating in 'Satellite Setting Panel'

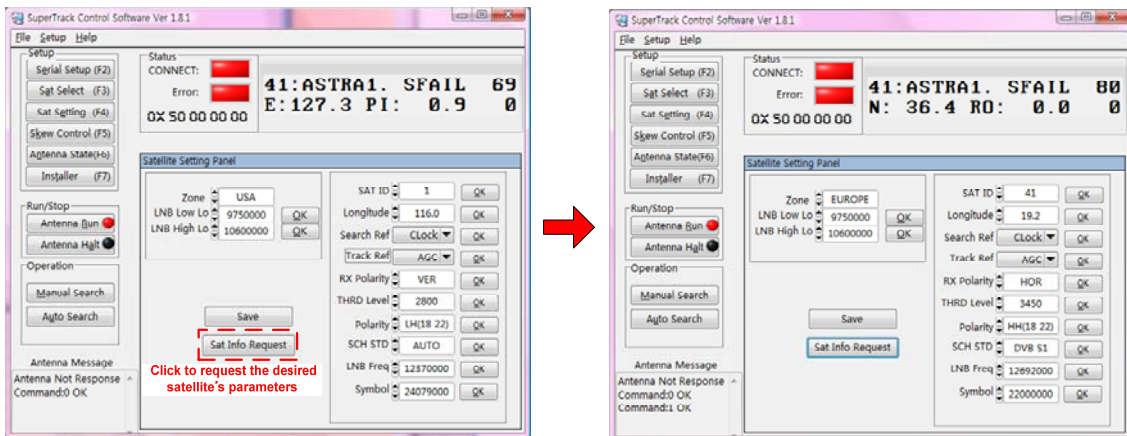

Change the 'LNB Freq', 'Symbol' like below Figure.

Click the 'OK' in right side of changed parameters to upload to PCU.

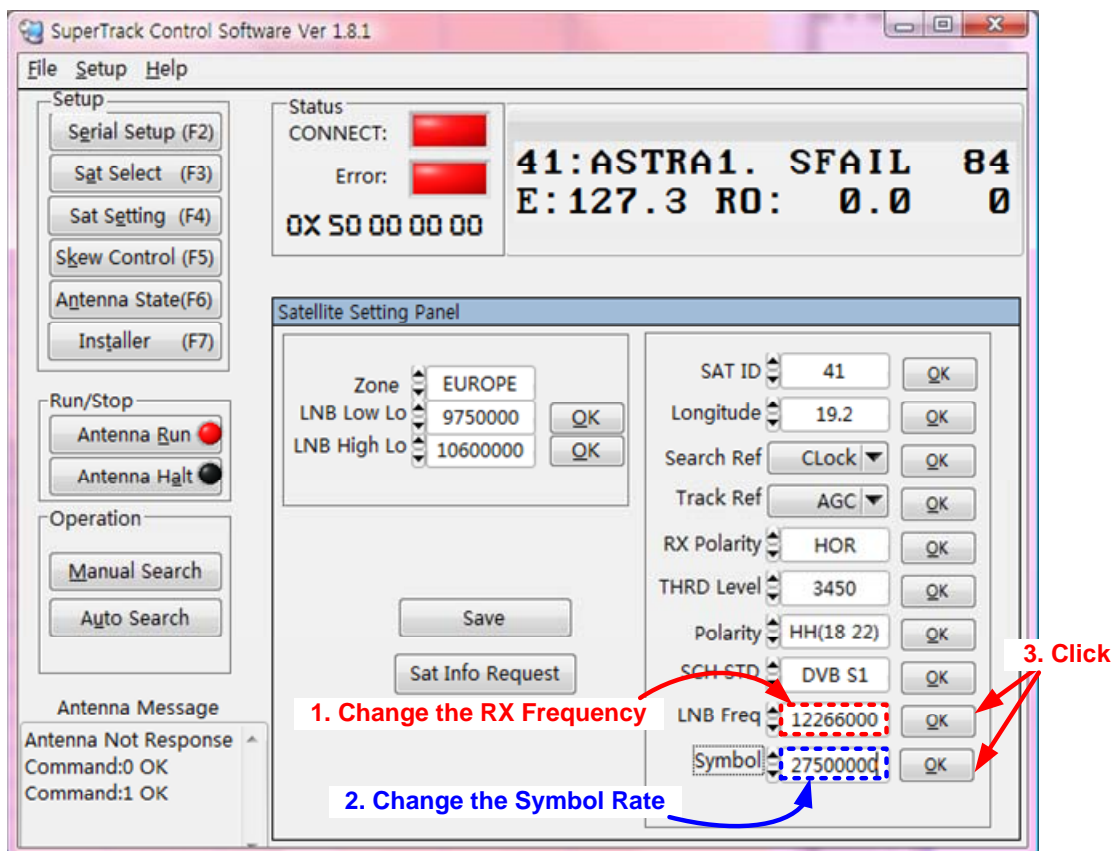



Click the 'SAVE' to save to PCU.

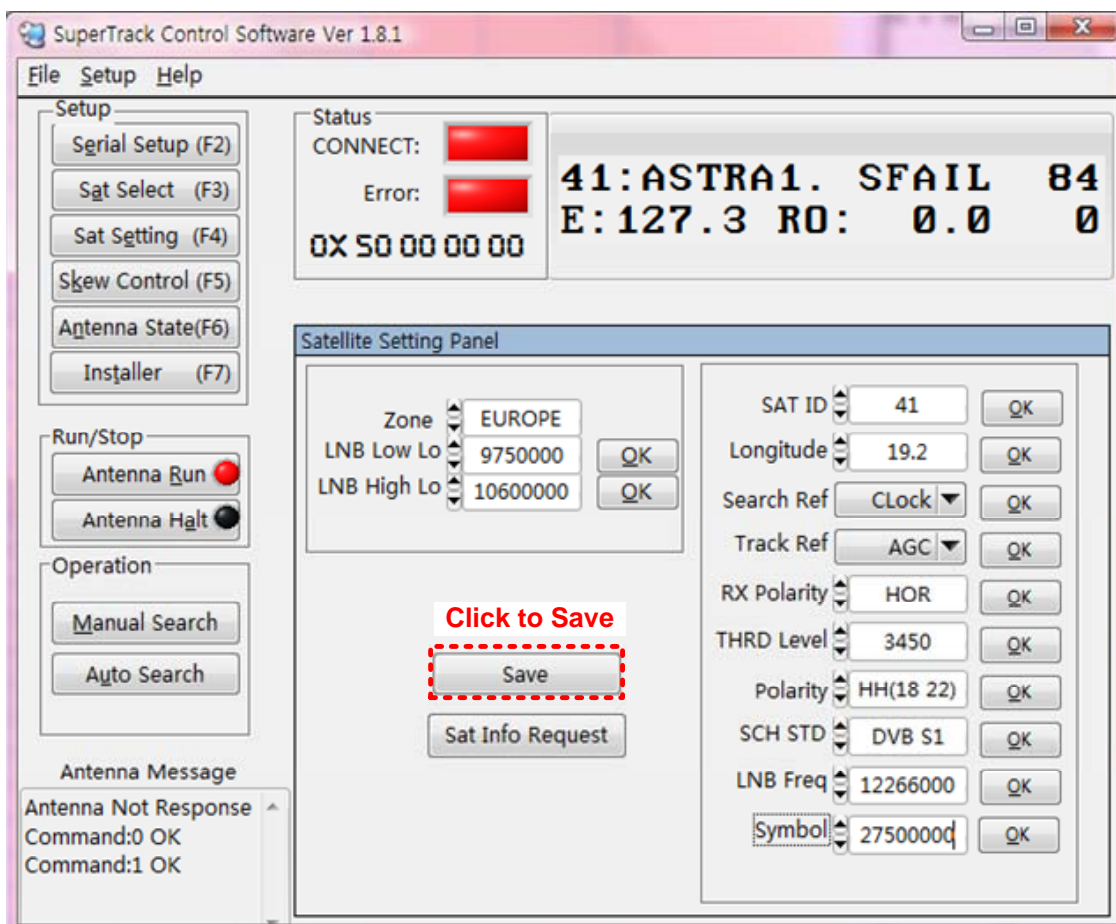

Click the 'Auto Search' to search the satellite

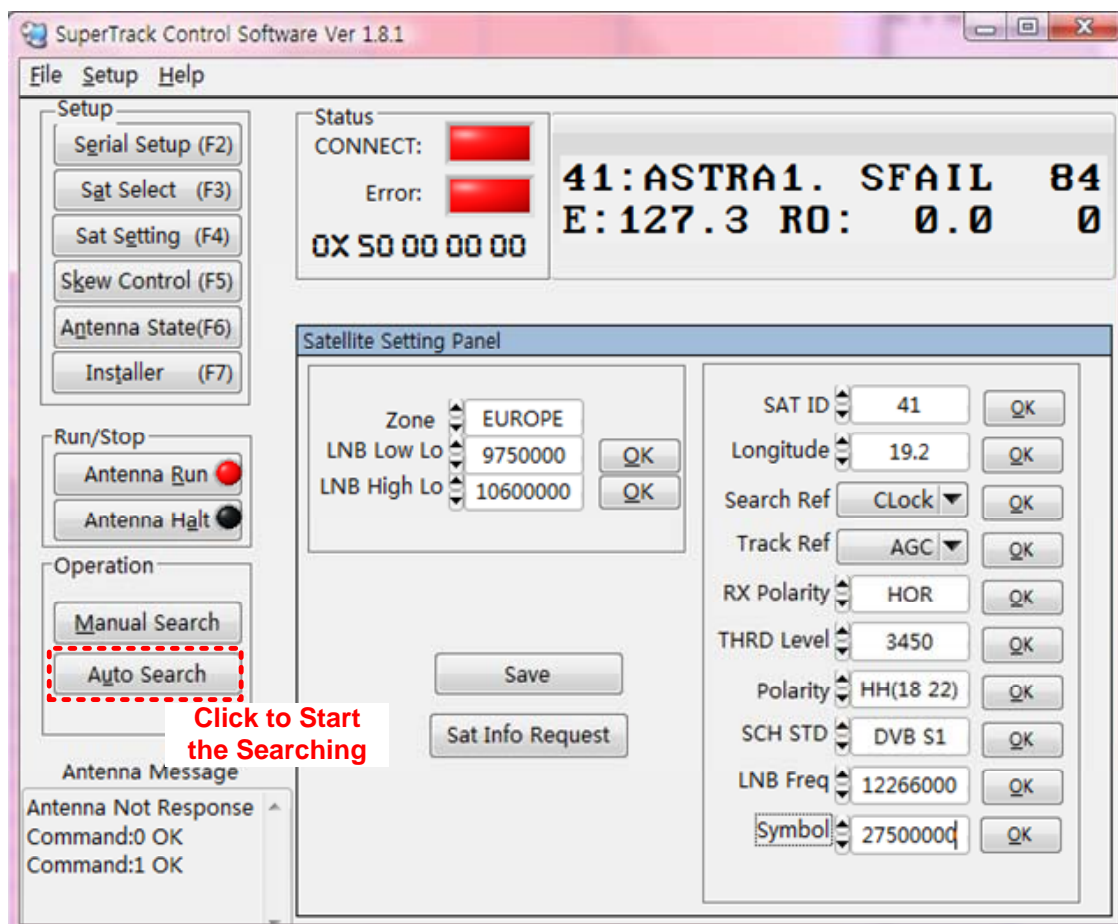

Then K5 search and track the desired satellite.

## Appendix B: Error Code Definition

If there is a problem with the antenna, you can check the error code on the ACU and SCS. Press the 'MENU' button on the front panel of the ACU when the error LED is on. Then, you will see the hexadecimal error code, as shown in Fig B-1 below. Also, you can see the binary error code when press the 'NEXT' button and hold for 3 seconds

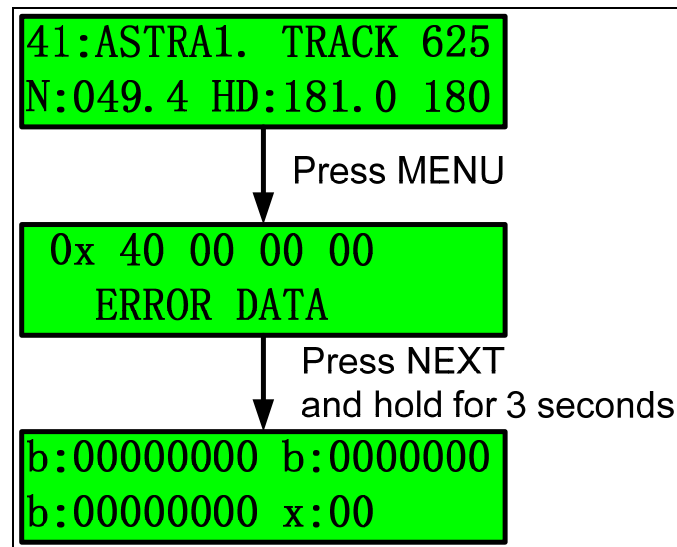

**Figure B-1 Error Code on ACU**

You will also be able to see the hexadecimal error code on the SCS V 1.8.1, as shown in Figure B-2 below.

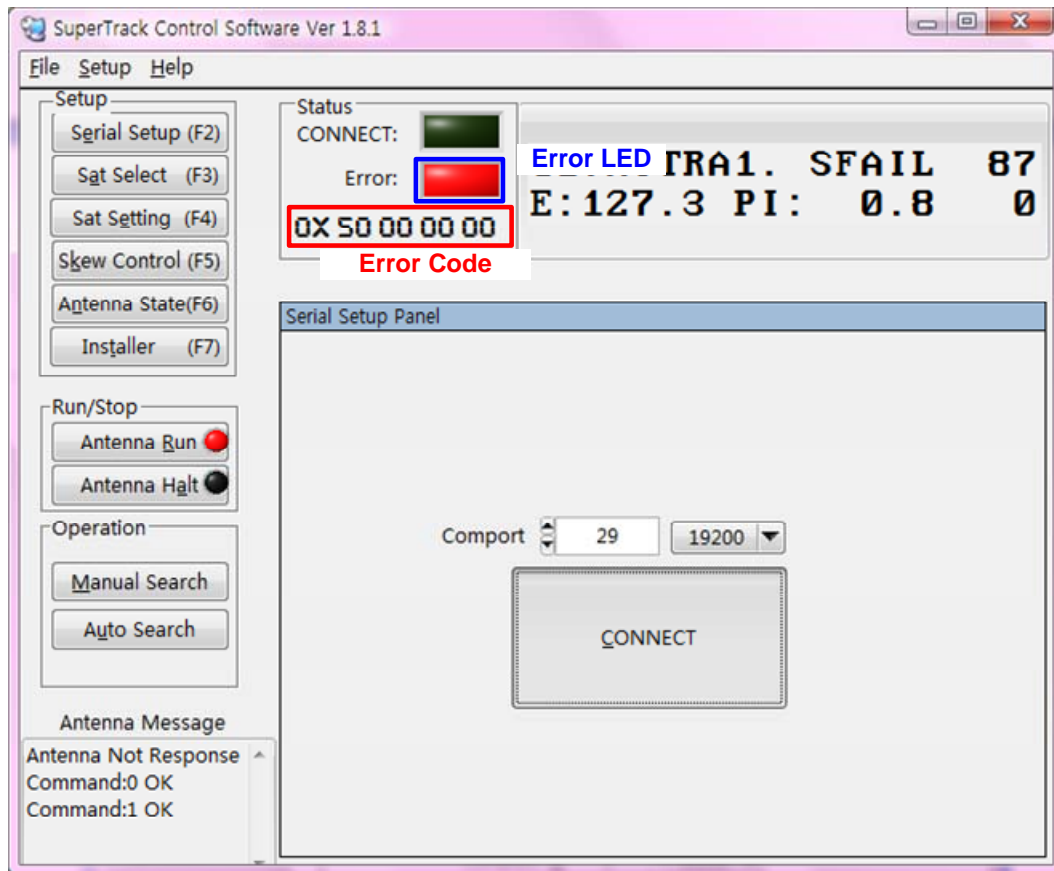

**Figure B-2 Error Code on SCS**

Table C-1 shows the error code definition, but this is a binary code. Thus, you must convert the hexadecimal code to a binary code to confirm the error.

EX 1) Hexadecimal error code: '0X 50 00 00 00'

Convert to binary error code: 0X 01010000 00000000 00000000 00

- ⇒ 1<sub>5</sub> error of FF<sup>(1)</sup> means that the satellite information is not acceptable (i.e. the satellite longitude or current antenna latitude and longitude information is not acceptable).
- ⇒ 1<sub>7</sub> error of FF<sup>(1)</sup> refers to searching fail.

EX 2) The hexadecimal error code: '0X 20 00 00 07'

Convert to the binary error code: 0X 00100000 00000000 00000000 07

- ⇒ Error refers to the 7<sup>th</sup> error of the DBS tuner error.
- ⇒ 07 means the LNB polarity voltage is not within the LNB polarity range. This could indicate that the LNB voltage is not switching or that the LNB voltage is shorted

# Error Code Define

PCU Version: after K 1.00

**Syntax: 0x: FF<sup>(1)</sup> FF<sup>(2)</sup> FF<sup>(3)</sup> FF<sup>(4)</sup>**

0x FF<sup>(1)</sup> =<sub>18</sub>1<sub>7</sub>1<sub>6</sub>1<sub>5</sub> 1<sub>4</sub>1<sub>3</sub>1<sub>2</sub>1<sub>1b</sub>

1<sub>1</sub>: Not used

1<sub>2</sub>: Not used

1<sub>3</sub>: Not used

1<sub>4</sub>: Not used

1<sub>5</sub>: Satellite information is not acceptable (satellite longitude or current antenna latitude, longitude information)(clear if normal state)

1<sub>6</sub>: DBS tuner error

1<sub>7</sub>: Searching fail

1<sub>8</sub>: Not used

0x FF<sup>(2)</sup> =<sub>18</sub>1<sub>7</sub>1<sub>6</sub>1<sub>5</sub> 1<sub>4</sub>1<sub>3</sub>1<sub>2</sub>1<sub>1b</sub>

1<sub>1</sub>: PCU DSP EEPROM reading or writing error

1<sub>2</sub>: Roll acceleration sensor not in valid range

1<sub>3</sub>: Pitch acceleration sensor not in valid range

1<sub>4</sub>: Roll gyro scope not in valid range

1<sub>5</sub>: Pitch gyro scope not in valid range

1<sub>6</sub>: yaw gyro scope not in valid range

1<sub>7</sub>: Ship Rotate over 50degree during initialization

1<sub>8</sub>: Not used

0x FF<sup>(3)</sup> =<sub>18</sub>1<sub>7</sub>1<sub>6</sub>1<sub>5</sub> 1<sub>4</sub>1<sub>3</sub>1<sub>2</sub>1<sub>1b</sub>

1<sub>1</sub>: Elevation Min Limit Switch error during initialize

1<sub>2</sub>: Skew Max Limit Switch error during initialize

1<sub>3</sub>: Skew Min Limit Switch error during initialize

1<sub>4</sub>: Azimuth Max Limit Switch error during initialize

1<sub>5</sub>: Azimuth Min Limit Switch error during initialize

1<sub>6</sub>: Not used

1<sub>7</sub>: Not used

1<sub>8</sub>: Not used

0x FF<sup>(4)</sup>

0x01: System has restarted

0x02: Not used

0x03: Not used

0x04: Not used.

0x05: Not used

0x06: A tuner I2C bus failure has occurred.

0x07: The LNB polarity voltage is not within the LNB polarity range. This could indicate that the LNB voltage is not switching or that the LNB voltage is shorted

0x08: The LNB signal level is below a valid range. Or this could indicate no LNB connected

**Table B-1 Error Code Definition**

**NOTE:** To clear the error by performace after checking the error, press the 'NEXT' button on the ACU.

## Appendix C: Specifications

Above Deck			
<b>Antenna Dish Diameter</b>	45cm (18")	<b>Antenna Dimensions</b>	53cm(H) x 51cm(D))
<b>Antenna Weight</b>	12Kg	<b>Radome Material</b>	Plastic
<b>Minimum EIRP</b>	49 dBW	<b>Azimuth Range</b>	690°
<b>Skew Control</b>	Automatic	<b>LNB</b>	Quattro/Quad, Circular(Optional)
<b>Ship's Motion</b>	Roll & Pitch $\pm 25^\circ$	<b>Tracking Speed</b>	More than 50°/ sec
<b>Platform</b>	3-axis	<b>Elevation Angle</b>	+7° to +85°
<b>GPS</b>	Yes	<b>Vibration Damper</b>	N/A
<b>DiSEqC</b>	DiSEqC 1.2	<b>Temperature</b>	-25°C to +55°C
<b>Humidity</b>	Up to 100% @ 40°C		
Below Deck			
<b>ACU Size</b>	290 x 160 x 44mm	<b>External I/O</b>	RS232C
<b>Input Power</b>	110/220 VAC	<b>Gyro Compass Input</b>	NMEA
Packing			
<b>Size</b>	52 x 52 x 67cm	<b>Gross Weight</b>	25Kg
<b>Packed by</b>	Paper carton		

Specifications subject to change without notice

## Appendix D: Satellite Information

### North America

Sat ID	Satellite Longitude	Satellite Name	Polarity & LO Band	NID	FEC Mode	FEC Rate	Frequency (KHz)	Symbol Rate(KHz)	Beam
01	061.5-W	EchoStar3	HH	0	DVBQ	Auto	12,574,000	21,500,000	Conus
02	072.5-W	DirecTV 1	RH	0	DVBQ	Auto	12,239,000	20,000,000	
03	082.0-W	Nimiq 4	RH	0	DVBQ	Auto	12,428,000	20,000,000	
04	091.0-W	Nimiq 1	RH	0	DVBQ	Auto	12,341,000	20,000,000	Canada
05	101.0-W	DirecTV1R	RH	0	DVBQ	Auto	12,224,000	20,000,000	
06	110.0-W	Echo810/Direc 5	RH	0	DVBQ	Auto	12,486,000	20,000,000	-
07	119.0-W	Echo7/Direc 7S	RH	0	DVBQ	Auto	12,370,000	20,000,000	Conus
08	121.0-W	Echostar9	HH	0	DVBQ	Auto	11,972,000	20,000,000	Ku
09	129.0-W	Ciel2	RH	0	DVBQ	Auto	12,457,000	21,500,000	Conus
10	072.0-W	AMC-6	VH	0	DVBQ	Auto	12,148,000	2,573,000	Ku
11	101.0-W	AMC4	HH	0	DVBQ	Auto	12,060,000	26,700,000	North& Central America
12	97.0-W	Galaxy19	HH	0	DVBQ	Auto	12,152,000	20,000,000	North America KU
13	89.0-W	Galaxy28	HH	0	DVBQ	Auto	11,787,000	15,915,000	North America KU
14	101.0-W	User 4	RH	0	DVBQ	Auto	12,224,000	20,000,000	
15	101.0-W	User 5	RH	0	DVBQ	Auto	12,224,000	20,000,000	
16	101.0-W	User 6	RH	0	DVBQ	Auto	12,224,000	20,000,000	
17	101.0-W	User 7	RH	0	DVBQ	Auto	12,224,000	20,000,000	
18	101.0-W	User 8	RH	0	DVBQ	Auto	12,224,000	20,000,000	
19	101.0-W	User 9	RH	0	DVBQ	Auto	12,224,000	20,000,000	
20	101.0-W	User 10	RH	0	DVBQ	Auto	12,224,000	20,000,000	



## South America

Sat ID	Satellite Longitude	Satellite Name	Polarity & LO Band	NID	FEC Mode	FEC Rate	Frequency (KHz)	Symbol Rate(KHz)	Beam
21	095.0-W	Galaxy3C	LL	0	DSSQ	Auto	11,690,000	20000000	Latin America
22	113.0-W	SatMex6	HH	0	DVBQ	Auto	12,080,000	25,645,000	Ku2
23	058.0-W	Intelsat9	HH	0	DVBQ	Auto	12,160,000	30,000,000	Mexico
24	058.0-W	User 1	HH	0	DVBQ	Auto	11,960,000	30,000,000	Mexico
25	058.0-W	User 2	HH	0	DVBQ	Auto	11,960,000	30,000,000	Mexico
26	058.0-W	User 3	HH	0	DVBQ	Auto	11,960,000	30,000,000	Mexico
27	058.0-W	User 4	HH	0	DVBQ	Auto	11,960,000	30,000,000	Mexico
28	058.0-W	User 5	HH	0	DVBQ	Auto	11,960,000	30,000,000	Mexico
29	058.0-W	User 6	HH	0	DVBQ	Auto	11,960,000	30,000,000	Mexico
30	058.0-W	User 7	HH	0	DVBQ	Auto	11,960,000	30,000,000	Mexico
31	058.0-W	User 8	HH	0	DVBQ	Auto	11,960,000	30,000,000	Mexico
32	058.0-W	User 9	HH	0	DVBQ	Auto	11,960,000	30,000,000	Mexico
33	058.0-W	User 10	HH	0	DVBQ	Auto	11,960,000	30,000,000	Mexico
34	058.0-W	User 11	HH	0	DVBQ	Auto	11,960,000	30,000,000	Mexico
35	058.0-W	User 12	HH	0	DVBQ	Auto	11,960,000	30,000,000	Mexico
36	058.0-W	User 13	HH	0	DVBQ	Auto	11,960,000	30,000,000	Mexico
37	058.0-W	User 14	HH	0	DVBQ	Auto	11,960,000	30,000,000	Mexico
38	058.0-W	User 15	HH	0	DVBQ	Auto	11,960,000	30,000,000	Mexico
39	058.0-W	User 16	HH	0	DVBQ	Auto	11,960,000	30,000,000	Mexico
40	058.0-W	User 17	HH	0	DVBQ	Auto	11,960,000	30,000,000	Mexico

## Europe

Sat ID	Satellite Longitude	Satellite Name	Polarity & LO Band	NID	FEC Mode	FEC Rate	Frequency (KHz)	Symbol Rate(KHz)	Beam
41	19.2E	Astra1H	HH	0	DVBQ	Auto	12,692,000	22,000,000	1H
42	28.2E	Astra2A	HH	0	DVBQ	Auto	11,836,000	27,500,000	2A North
43	28.2.0E	Astra2B	HH	0	DVBQ	Auto	12,032,000	27,500,000	2B South
44	30.0W	Hispasat 1C	HH	0	DVBQ	Auto	11,931,000	27,500,000	Europe
45	13.0E	Hotbird9	HH	0	DVBQ	Auto	12,654,000	27,500,000	Europe
46	13.0E	Hotbird8	HH	0	DVBQ	Auto	12,015,000	27,500,000	Europe
47	4.8E	SiriuK5	HH	0	DVBQ	Auto	11,919,000	27,500,000	Nordic BSS
48	0.8W	Thor3	HH	0	DVBQ	Auto	12,476,000	28,000,000	Nordic & Central, Eastern Europe
49	26.0E	Bard6	HH	0	DVBQ	Auto	11,843,000	27,500,000	BSS
50	7.0W	Nilesat102	HH	0	DVBQ	Auto	11,996,000	27,500,000	Middle East
51	42.0E	Turksat2A	HH	0	DVBQ	Auto	12,015,000	27,500,000	East
52	7.0E	Eutelsat W3A	HH	0	DVBQ	Auto	12,690,000	2,894,00	Europe B
53	15.8E	Eutelsat Seasat1	HH	0	DVBQ	Auto	12,525,000	30,000,00	Fixed
54	10.0E	Eutelsat W2A	HH	0	DVBQ	Auto	12,522,000	2,893,000	Europe
55	39.0E	Hellasat2	HH	0	DVBQ	Auto	12,524,000	30,000,000	F1
56	5.0W	Atlantic Bird 3	HH	0	DVBQ	Auto	12,543,000	27,500,000	Super
57	4.0W	Amos3	HL	0	DVBQ	Auto	11,389,000	27,500,000	Europe H
58	23.5E	Astra2ConL	HL	0	DVBQ	Auto	10,803,000	22,000,000	1E H FSS
59	23.5E	Astra2ConH	HH	0	DVBQ	Auto	10,983,600	8,052,000	F2
60	39.0E	Ipcopter	HL	0	DVBQ	Auto	11,514,000	3,000,000	F2

## Asia

Sat ID	Satellite Longitude	Satellite Name	Polarity & LO Band	NID	FEC Mode	FEC Rate	Frequency (KHz)	Symbol Rate(KHz)	Beam
61	116.0E	KOR3	HH	0	DVBQ	Auto	11,747,000	21,300,000	South Korea
62	110.0E	N-Sat 110	LH	0	DVBQ	Auto	12,551,000	29,915,000	Japan
63	75.0E	ABS1	HH	0	DVBQ	Auto	12,579,000	22,000,000	South
64	128.0E	JCSAT3A	HH	0	DVBQ	Auto	12,408,000	21,096,000	
65	124.0E	JCSAT4A	HH	0	DVBQ	Auto	12,432,000	21,096,000	Japan
66	166.0E	Intelsat8	HH	0	DVBQ	Auto	12,462,000	2,222,000	NE Asia
67	144.0E	Superbird C2	VH	0	DVBQ	Auto	12,508,000	21,096,000	Japan
68	95.0E	NSK5	HH	0	DVBQ	Auto	12,647,000	27,500,000	India
69	156.0E	Optus C1	HH	0	DVBQ	Auto	12,689,000	27,800,000	NB
70	160.0E	Optus D1	HH	0	DVBQ	Auto	12,613,000	14,294,000	NB
71	152.0E	Optus D2	HH	0	DVBQ	Auto	12,644,000	22,500,000	NANZ
72	95.0E	NSK5	HH	0	DVBQ	Auto	12,729,000	26,400,00	NE Asia
73	95.0E	NSK5	HL	0	DVBQ	Auto	11,676,000	27,500,000	SE Asia
74	108.2E	NSS11	HH	0	DVBQ	Auto	12,431,000	30,000,000	NE Asia
75	88.0E	ST1	HH	0	DVBQ	Auto	12,642,000	24,000,000	K1
76	78.5E	Thaicom5	HH	0	DVBQ	Auto	12,720,000	30,000,000	Thailand
77	146.0E	ABS5	HH	0	DVBQ	Auto	12,581,000	25,600,000	Ku
78	91.5E	Measat3	HH	0	DVBQ	Auto	12,523,000	27,500,000	South Asia
79	105.5E	Asiasat 3S	VH	0	DVBQ	Auto	12,683,000	5,800,000	South Asia
80	132.0E	Vinasat1	H	0	DVBQ	Auto	11,090,000	28,125,000	Ku

# Appendix E: Radome and Antenna Mounting Holes Layout

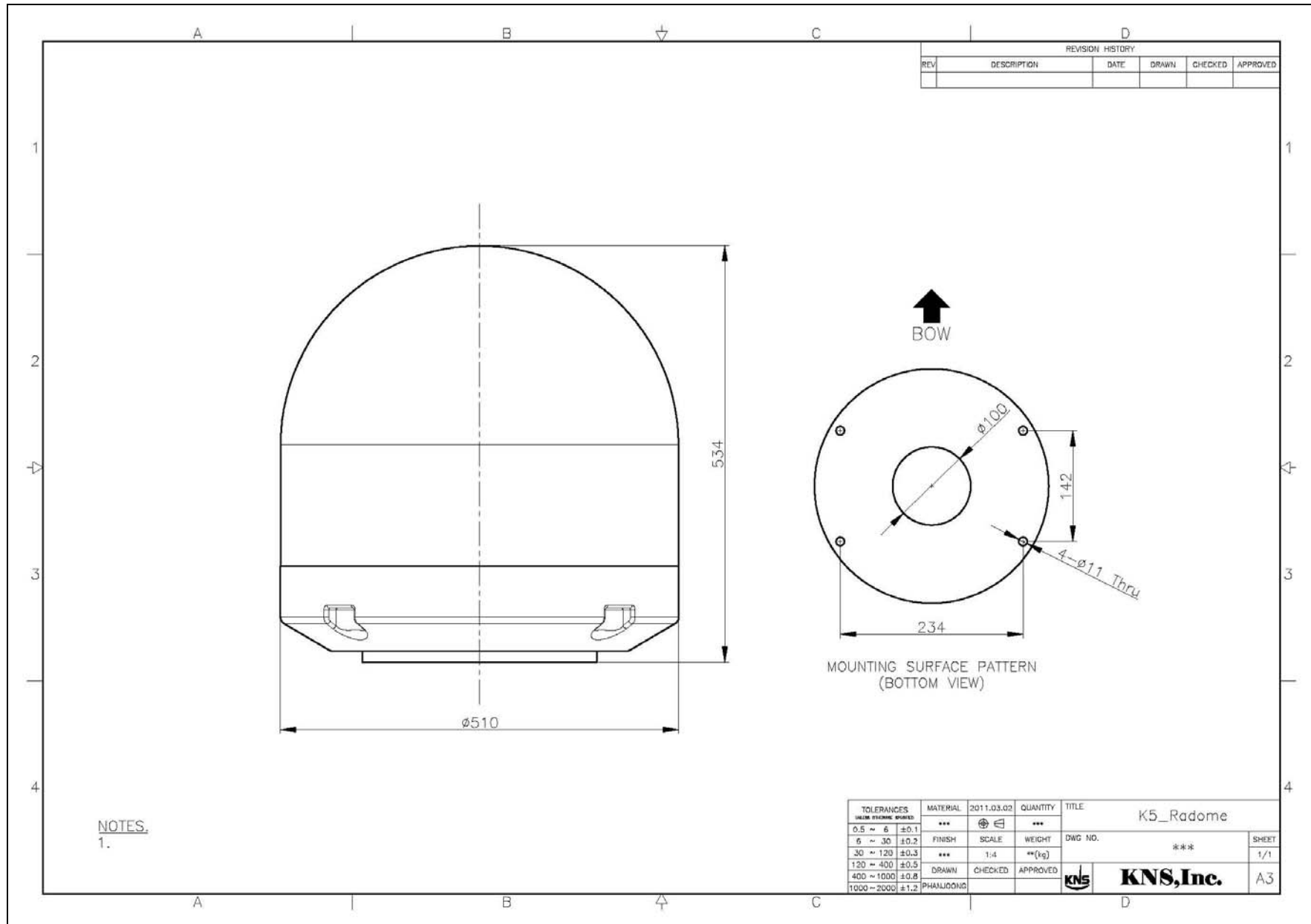

Figure E-1 K5 Plastic Radome Layout